

SB-250

One-station positioner.

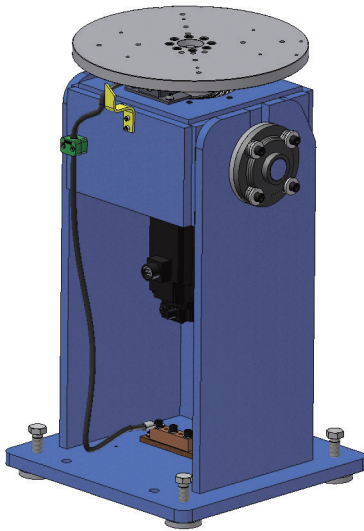

- Space saving design.
- Direct drive.
- Endelss rotation.

This is one station positioner for workpieces requiring rotation about one axis. It is a stand alone positioner to be used without tailstock and suitable for integration in e.g. compact welding stations.

The SB positioner can have its rotating fixture disc tilted in five positions from horizontal to vertical. The position of the fixture disc is changed manually.

The SB positioner is suitable for workpieces with a diameter up to 1300 mm.

Technical data		SB-250 SD
Max. payload		250 kg
Maximum fixture width, radius = H		655 mm
Welding capacity	100% duty cycle 60% duty cycle	350 A 460 A
Rotating axis torque	dynamic static	1046 Nm 837 Nm
Rotating axis rated speed		0-16.5 rpm
Rated offset from centre of gravity (COG)		341 mm
Weight		270 kg
Part No.		124600-101

Controlled by
YRC1000

Controlled by
DX200

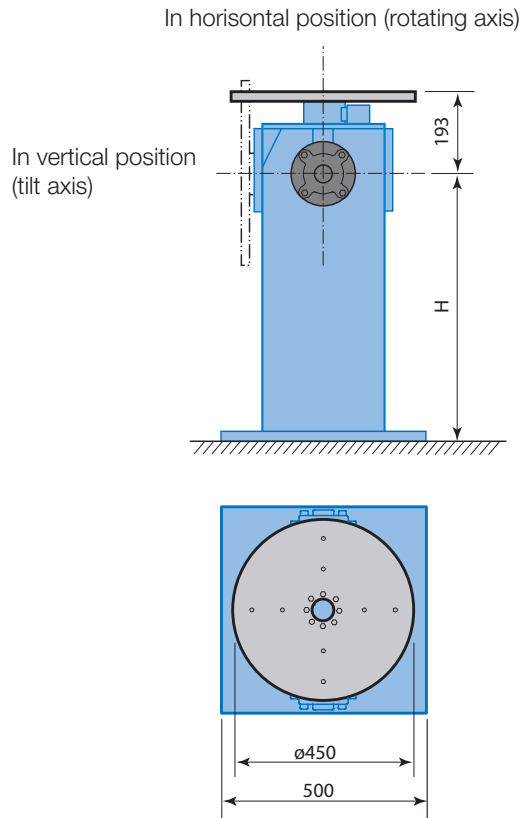

Possible positions

Horizontal and vertical, plus tilted in 22.5°, 45° and 67.5°.

YASKAWA



YASKAWA Nordic AB
PO Box 504
SE-385 25 Torsås, SWEDEN

Phone +46 480 41 78 00
info.se@yaskawa.eu.com
www.yaskawa.eu.com