

HTC-500, HTC-1000

Head- and tailstock positioner with horizontal rotation.

One station positioner for workpieces requiring rotation about one axis. Head- and tailstock with MotoMount fixture mounting system mounted on a bed. The distance between headstock and tailstock is fixed.

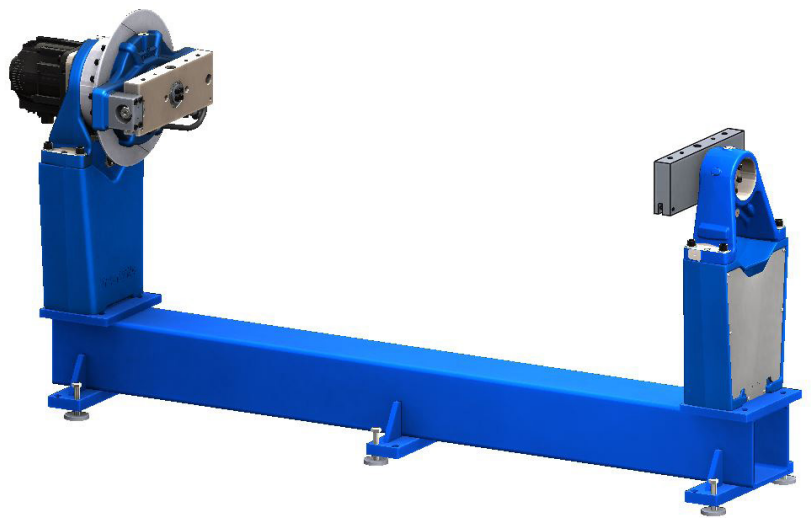

Technical data		HTC-500Y		HTC-1000Y	
Max. capacity	load	500 kg		1000 kg	
	offset	150 mm		150 mm	
Motor power		1.3 kW		3.0 kW	
Gear ratio	reducer	165:1		170:1	
Speed	nominal	9.0 rpm		8.8 rpm	
	maximum	23 rpm		23 rpm	
Torque	rated	1177 Nm		2689 Nm	
	continuous rated	941 Nm		2151 Nm	
	peak	2354 Nm		5378 Nm	
Rated welding current Standard	100%	350 A		350 A	
	60%	460 A		460 A	
Rated welding current Option	100%	860 A		860 A	
	60%	1120 A		1120 A	
	35%	1380 A		1380 A	
Max fixture width	diameter	1250	1650	1250	1650
Part No.		141510-xxx	141512-xxx	141514-xxx	141516-xxx

New generation
Sigma-7

Fixture holder
MotoMount

Controlled by
YRC1000

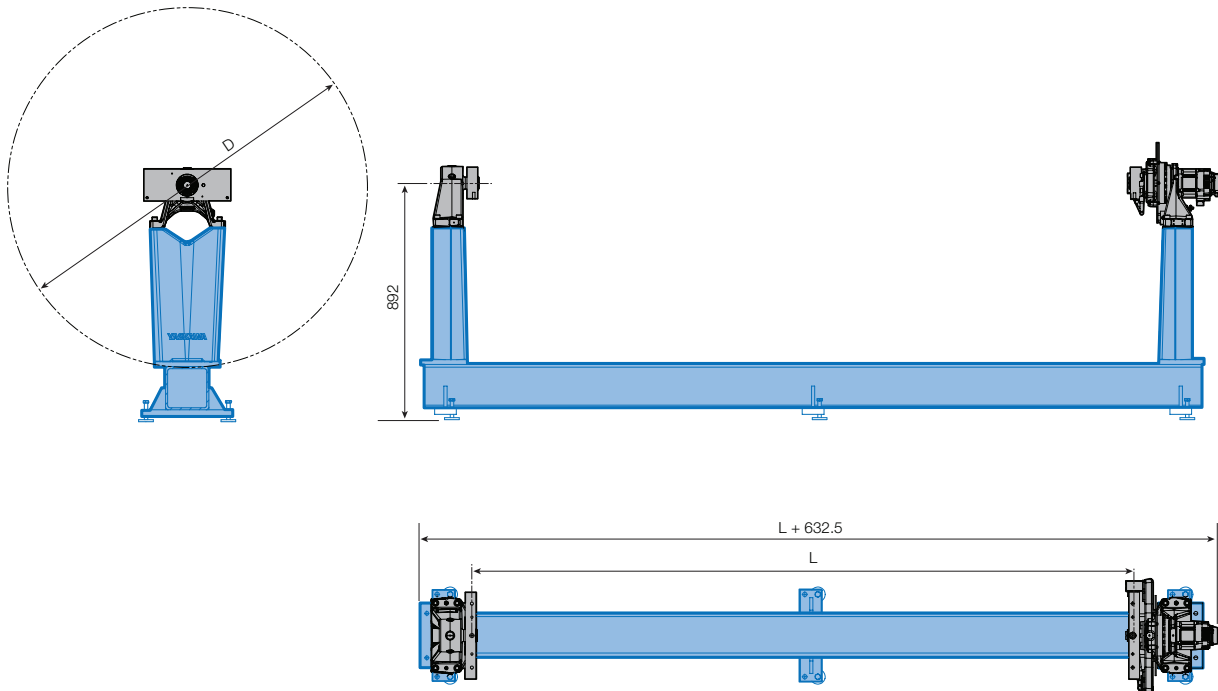

Type	L	D	Part No.
HTC-500Y	2050	1250	141510-701
		1650	141512-701
	3050	1250	141510-704
		1650	141512-704
	4050	1250	141510-706
		1650	141512-706
<i>Other lengths on demand.</i>			
HTC-1000Y	2050	1250	141514-701
		1650	141516-701
	3050	1250	141514-704
		1650	141516-704
	4050	1250	141514-706
		1650	141516-706
<i>Other lengths on demand.</i>			