

ArcWorld CS V2-500

turnkey system

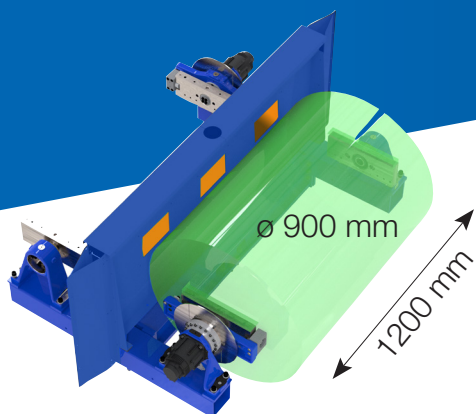

ArcWorld CS is an extremely successful CE-marketed, platform based robotic arc welding station. Designed for fast-track installation and commissioning, with a highly productive output. Available for one or two robots and a variety of customised configurations.

Key benefits

- Short delivery times.
- Easy to install, and to relocate.
- Easy to operate.
- Small footprint, but generous fixture space.
- Using an overhead crane to load material.
- Full visibility through anti-UV windows.
- Possible to use a "Virtual twin".
- TIG, MIG or MAG welding possible.
- Factory preset options.

Fast-track to operation

You can begin production immediately upon delivery. Simply connect the electrical power, exhaust extraction, gas, and wire at back of the ArcWorld. Robot jobs can be made in advance, and the platform design facilitates seamless transfer of jobs from the offline programming and virtual twin to the robot on site.

Designed for easy access

Featuring a unique design, the curved sliding doors open and close automatically and the open space above allows for overhead crane loading. The operator workspace is carefully engineered to minimize the steps required for loading and unloading. This innovative approach puts operator benefits first.

Easy to relocate

With its platform design, integrated wheels and forklift pockets, the ArcWorld CS is easy to relocate from one place to another within your facility. Giving the option of flexibility, while maintaining optimal efficiency depending on your needs.

Controlled by
YRC1000

New generation
Sigma-7

Fixture holder
MotoMount

Operator workspace

Designed with a strong emphasis on ergonomics and the working environment. ArcWorld CS features a highly efficient fume extraction with integrated ventilation ducts and extraction slots in both the welding and loading areas. Optimal lighting in both the operator and robot zones, and anti-UV windows which provide operators with an excellent view into the ArcWorld.

Options and factory preset

Adjusted from factory to meet your specific requirements with a wide range of power sources and welding options. Other options are twin robot systems, service door on either side, media transfer (signal, air) for fixtures, manual rotation of the positioner and MotoSim software for offline programming an ArcWorld CS virtual twin model.



ArcWorld CS V2-500Y3
L=1300 pin-to-pin

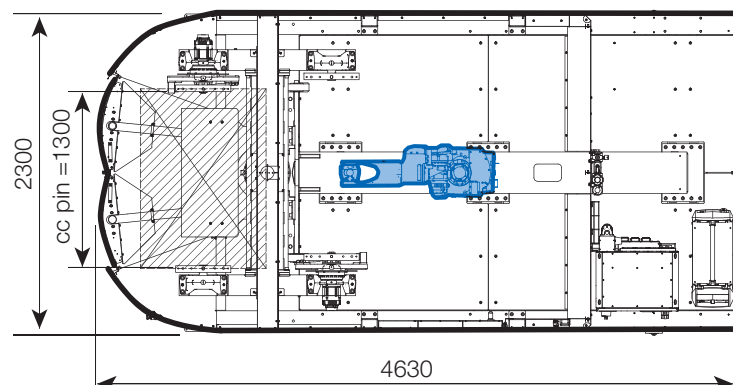
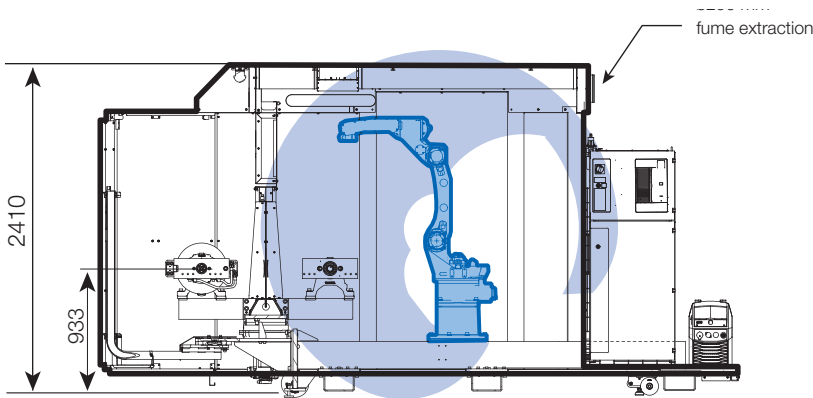

Technical data	V2-500Y3
Payload	500 kg/station
Workpiece width	1200 mm
Workpiece diameter	ø 900 mm

*All dimensions are for reference only.
Always request detailed drawings for design and engineering requirements.*

YASKAWA Nordic AB
PO Box 504
SE-385 25 Torsås, SWEDEN



Phone +46 480 41 78 00
info.se@yaskawa.eu
www.yaskawa.eu.com

© YASKAWA Nordic AB · RegNo. 6637EN-01, March 2025
Technical data may be subject to change without previous notice.

ArcWorld

LESS SPACE | MORE OUTPUT

YASKAWA