

V2-1000 Y3

Two station positioner with vertical indexing.

Two station positioner for workpieces requiring rotation about one axis. It has been designed for operator ease of use, with a suitable working height for loading and unloading the fixtures, and is delivered complete with an anti-glare shield.

The head- and tailstock modules are equipped with MotoMount fixture mounting system.



Technical data		V2-1000 Y3	
Max. capacity	load per station	1000 kg	
Max fixture width	diameter	1300 mm	1600 mm
Distance between fixture pin-pin		2050, 2550 mm	2050, 2550 mm
Index axis	Motor power	3.7 kW	
	Torque dynamic	4756 Nm	
	Torque static	3805 Nm	
	Index (station changing) time 0-180°	4.8 sec	
Rotating axis	Motor power	3.0 kW	
	Torque dynamic	2689 Nm	
	Torque static	2151 Nm	
	Offset	219 mm	
	Rotating time 0-90°	1.1 sec	
	Rotating time 0-180°	1.8 sec	
	Rotating time 0-360°	3.1 sec	

New generation
Sigma-7

Fixture holder
MotoMount

Controlled by
YRC1000

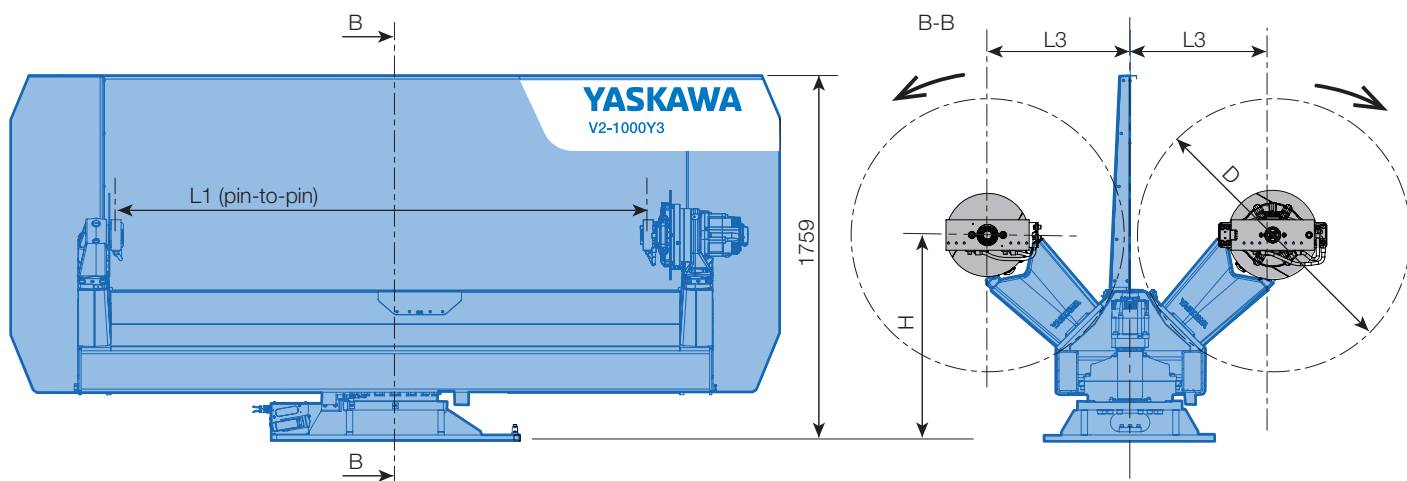

Part No.	D	L1	L3	H	Weight
164208-701	ø 1300 mm	2050 mm	686 mm	991 mm	1690 kg
164208-702	ø 1300 mm	2550 mm	686 mm	991 mm	1720 kg
165572-701	ø 1600 mm	2050 mm	827 mm	1133 mm	1750 kg
165572-702	ø 1600 mm	2550 mm	827 mm	1133 mm	1780 kg

Options	Part No.
2x 3/8" air	137779-200
2x 3/8" air + Signal kit 4 channel I/O Fieldbus+PE	137779-201
2x 3/8" air + Signal kit 4 channel I/O ProfiNet+PE	137779-202
2x 3/8" air + Signal kit 12 channel I/O+PE	137779-203
2x 3/8" air + Signal kit 24 channel I/O+PE	137779-204
2x 3/8" Controlled air	137779-400
2x 3/8" Controlled-air+ Signal kit 4 channel I/O Fieldbus+PE	137779-401
2x 3/8" Controlled-air+ Signal kit 4 channel I/O ProfiNet+PE	137779-402
2x 3/8" Controlled-air+ Signal kit 12 channel I/O+PE	137779-403
2x 3/8" Controlled-air+ Signal kit 24 channel I/O+PE	137779-404
Retrofit adapter for fixtures (Length = L -130)	Headstock Tailstock 2x 143073-100 2x 143074-100
Enhanced welding capacity	140375-101