

LA700

The Lift Drive

YASKAWA

Key features

- Super-smooth ride comfort
- Quieter operation thanks to new frequency adjustment function
- Advanced light load search for evacuation (smaller UPS)
- SIL3 STO (Zero contactor solution)
- BiSS support
- Integrated Class C2 EMC filter
- Coated PCBs according to 3C2, 3S2 by default
- Embedded braking chopper
- Fast installation and setup
- Smart replacement
- Motor tuning in stand-still condition without removing ropes
- For gearless and geared lifts
- Up to 4 m/s

Advanced functions

- Direct to floor
- Monitors for motor temperature, peak current and lifetime
- Advanced short floor management
- Elevator setup wizard
- Support for 13 languages
- Torque compensation with load cell
- Operation with motor encoder [optional]



Designed for
10 YEARS
of maintenance
free operation

Best value for lift

Yaskawa LA700 lift drives are the solution to technical requirements of today's elevators. This lift drive controls induction and permanent magnet motors. It is the first choice for new installation, machine room less lifts, but also for modernization. Experience the proven Yaskawa reliability combined with a new level of ride comfort.

Catalog Code

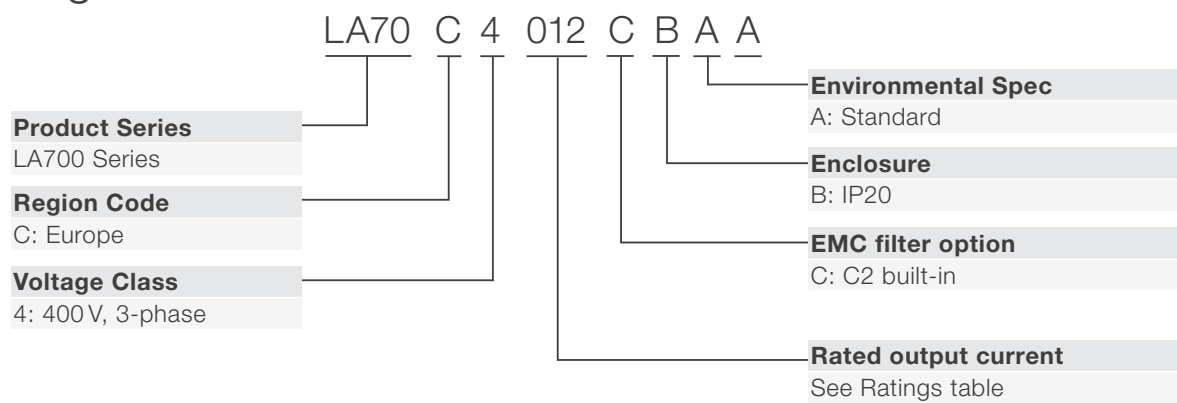

Ratings

Catalog Code LA70C	Max Appl. Motor Power (HD) [kW]	50% ED Rated Output Current [A]	Dimensions [mm]			Weight [kg]
			W	H	D	
4012	4.0	11.5	140	260	211	3.9
4019	5.5	18.5				4.2
4023	7.5	22.5				
4030	11	30.0	180	300	202	6.0
4039	15	38.8				

YASKAWA Europe GmbH

Philipp-Reis-Str. 6
65795 Hattersheim am Main
Germany

+49 6196 569-500
support@yaskawa.eu
www.yaskawa.eu.com

10/2023
YEU_INV_LA700F_EN_v1

Specifications are subject to change without notice for ongoing product modifications and improvements. © YASKAWA Europe GmbH. All rights reserved.

YASKAWA