

$\Sigma$ -7-Series AC Servo Drive

# Rotary Servomotor with 400 V-Input Power Product Manual

Model: SGM7J, SGM7A, SGM7G

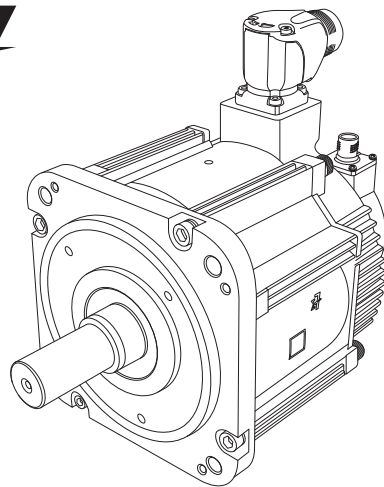

Basic Information on Servomotors

1

Capacity Selection

2

Specifications, Ratings, and  
External Dimensions of SGM7J Servomotors

3

Specifications, Ratings, and  
External Dimensions of SGM7A Servomotors

4

Specifications, Ratings, and  
External Dimensions of SGM7G Servomotors

5

Servomotor Installation

6

Connections between  
Servomotors and SERVOPACKs

7

Maintenance and Inspection

8

Appendices

9

Copyright © 2015 YASKAWA ELECTRIC CORPORATION

---

All rights reserved. No part of this publication may be reproduced, stored in a retrieval system, or transmitted, in any form, or by any means, mechanical, electronic, photocopying, recording, or otherwise, without the prior written permission of Yaskawa. No patent liability is assumed with respect to the use of the information contained herein. Moreover, because Yaskawa is constantly striving to improve its high-quality products, the information contained in this manual is subject to change without notice. Every precaution has been taken in the preparation of this manual. Nevertheless, Yaskawa assumes no responsibility for errors or omissions. Neither is any liability assumed for damages resulting from the use of the information contained in this publication.

## About this Manual

This manual provides information required to select, install, connect, and maintain Rotary Servomotors for  $\Sigma$ -7-Series AC Servo Drives.

Read and understand this manual to ensure correct usage of the  $\Sigma$ -7-Series AC Servo Drives.

Keep this manual in a safe place so that it can be referred to whenever necessary.

## Outline of Manual

The contents of the chapters of this manual are described in the following table.

Refer to these chapters as required.

Chapter	Chapter Title	Contents
1	Basic Information on Servomotors	Provides basic information on Rotary Servomotors, including Servomotor part names and combinations with SERVOPACKs.
2	Capacity Selection	Describes calculation methods to use when selecting Servomotor capacities.
3	Specifications, Ratings, and External Dimensions of SGM7J Servomotors	Describes how to interpret the model numbers of SGM7J Servomotors and gives their specifications, ratings, and external dimensions.
4	Specifications, Ratings, and External Dimensions of SGM7A Servomotors	Describes how to interpret the model numbers of SGM7A Servomotors and gives their specifications, ratings, and external dimensions.
5	Specifications, Ratings, and External Dimensions of SGM7G Servomotors	Describes how to interpret the model numbers of SGM7G Servomotors and gives their specifications, ratings, and external dimensions.
6	Servomotor Installation	Describes the installation conditions, procedures, and precautions for Servomotors.
7	Connections between Servomotors and SERVOPACKs	Describes the cables that are used to connect the Servomotors and SERVOPACKs and provides related precautions.
8	Maintenance and Inspection	Describes the maintenance, inspection, and disposal of a Servomotor.
9	Appendices	Provide additional information on Servomotors with Gears and reference information on selecting Servomotor capacity.

# Related Documents

The relationships between the documents that are related to the Servo Drives are shown in the following figure. The numbers in the figure correspond to the numbers in the table on the following pages. Refer to these documents as required.

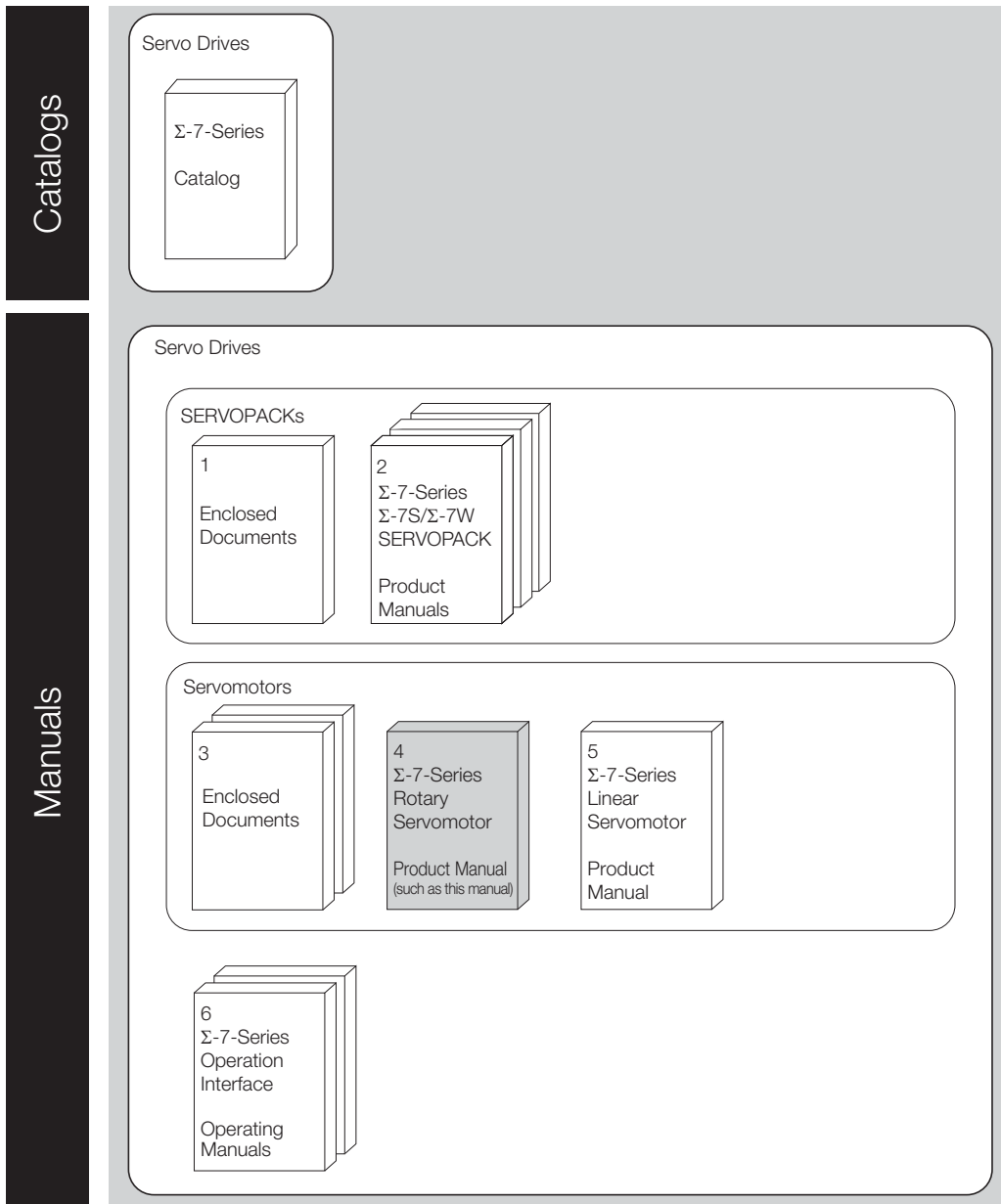

Classification	Document Name	Document No.	Description
1 Enclosed Document	$\Sigma$ -7-Series AC Servo Drive $\Sigma$ -7S SERVOPACK with 400 V-Input Power Safety Precautions	TOMP C710828 02	Provides detailed information for the safe usage of $\Sigma$ -7-Series SERVOPACKs.
2 $\Sigma$ -7-Series $\Sigma$ -7S/ $\Sigma$ -7W SERVOPACK Product Manuals	$\Sigma$ -7-Series AC Servo Drive $\Sigma$ -7S SERVOPACK with 400-V Input Power and EtherCAT (CoE) Communications References Product Manual	SIEP S800001 80	Provide detailed information on selecting $\Sigma$ -7-Series SERVOPACKs and information on installing, con- necting, setting, performing trial operation for, tuning, monitoring, and maintaining the Servo Drives.
	$\Sigma$ -7-Series AC Servo Drive $\Sigma$ -7S SERVOPACK with 400 V-Input Power and MECHATROLINK-III Communications References RJ-45 Connectors Product Manual	SIEP S800002 14	
	$\Sigma$ -7-Series AC Servo Drive $\Sigma$ -7W SERVOPACK with 400-V-Input Power and EtherCAT (CoE) Communications References Product Manual	SIEP S800002 19	
	$\Sigma$ -7-Series AC Servo Drive $\Sigma$ -7W SERVOPACK with 400 V-Input Power and MECHATROLINK-III Communications References RJ-45 Connectors Product Manual	SIEP S800002 20	
3 Enclosed Documents	AC Servo Drive Rotary Servomotor Safety Precautions	TOBP C230260 00	Provides detailed information for the safe usage of $\Sigma$ -7-Series Rotary Servomotors and Direct Drive Ser- vomotors.
	AC Servomotor Linear $\Sigma$ Series Safety Precautions	TOBP C230800 00	Provides detailed information for the safe usage of $\Sigma$ -7-Series Linear Servomotors.
4 $\Sigma$ -7-Series Rotary Servomotor Product Manual	$\Sigma$ -7-Series AC Servo Drive Rotary Servomotor with 400 V-Input Power Product Manual	This manual (SIEP S800001 86)	Provide detailed information on selecting, installing, and connecting the $\Sigma$ -7-Series Servomotors.
5 $\Sigma$ -7-Series Linear Servomotor Product Manual	$\Sigma$ -7-Series AC Servo Drive Linear Servomotor with 400 V-Input Power Product Manual	SIEP S800001 81	

Continued on next page.

---

Continued from previous page.

Classification	Document Name	Document No.	Description
6 Σ-7 Series Operation Interface Operating Manuals	Σ-7-Series AC Servo Drive Digital Operator Operating Manual	SIEP S800001 33	Describes the operating procedures for a Digital Operator for a Σ-7-Series Servo System.
	AC Servo Drive Engineering Tool SigmaWin+ Operation Manual	SIET S800001 34	Provides detailed operating procedures for the SigmaWin+ Engineering Tool for a Σ-7-Series Servo System.

# Using This Manual

## ◆ Technical Terms Used in This Manual

The following terms are used in this manual.

Term	Meaning
Servomotor	A $\Sigma$ -7-Series Rotary Servomotor.
SERVOPACK	A $\Sigma$ -7-Series $\Sigma$ -7S Servo Amplifier.
Servo Drive	The combination of a Servomotor and SERVOPACK.
Main Circuit Cable	One of the cables that connect to the main circuit terminals, including the Main Circuit Power Supply Cable, Control Power Supply Cable, and Servomotor Main Circuit Cable.

## ◆ Trademarks

- MECHATROLINK is a trademark of the MECHATROLINK Members Association.
- QR code is a trademark of Denso Wave Inc.
- Other product names and company names are the trademarks or registered trademarks of the respective company. "TM" and the ® mark do not appear with product or company names in this manual.

## ◆ Visual Aids

The following aids are used to indicate certain types of information for easier reference.



Indicates precautions or restrictions that must be observed.  
Also indicates alarm displays and other precautions that will not result in machine damage.



Indicates definitions of difficult terms or terms that have not been previously explained in this manual.

**Example** Indicates operating or setting examples.

**Information** Indicates supplemental information to deepen understanding or useful information.

---

# Safety Precautions

## ◆ Safety Information

To prevent personal injury and equipment damage in advance, the following signal words are used to indicate safety precautions in this document. The signal words are used to classify the hazards and the degree of damage or injury that may occur if a product is used incorrectly. Information marked as shown below is important for safety. Always read this information and heed the precautions that are provided.

### **DANGER**

- Indicates precautions that, if not heeded, are likely to result in loss of life, serious injury, or fire.

### **WARNING**

- Indicates precautions that, if not heeded, could result in loss of life, serious injury, or fire.

### **CAUTION**

- Indicates precautions that, if not heeded, could result in relatively serious or minor injury, or in fire.

### **NOTICE**

- Indicates precautions that, if not heeded, could result in property damage.



## ◆ Safety Precautions That Must Always Be Observed

### ■ General Precautions



## DANGER

- Read and understand this manual to ensure the safe usage of the product.
- Keep this manual in a safe, convenient place so that it can be referred to whenever necessary. Make sure that it is delivered to the final user of the product.
- Do not remove covers, cables, connectors, or optional devices while power is being supplied to the SERVOPACK.  
There is a risk of electric shock, operational failure of the product, or burning.



## WARNING

- Connect the ground terminals on the SERVOPACK and Servomotor to ground poles according to local electrical codes (100  $\Omega$  or less for a SERVOPACK with a 100-VAC or 200-VAC power supply, and 10  $\Omega$  or less for a SERVOPACK with a 400-VAC power supply).  
There is a risk of electric shock or fire.
- Do not attempt to disassemble, repair, or modify the product.  
There is a risk of fire or failure.  
The warranty is void for the product if you disassemble, repair, or modify it.



## CAUTION

- The SERVOPACK heat sinks, regenerative resistors, External Dynamic Brake Resistors, Servomotors, and other components can be very hot while power is ON or soon after the power is turned OFF. Implement safety measures, such as installing covers, so that hands and parts such as cables do not come into contact with hot components.  
There is a risk of burn injury.
- Do not damage, pull on, apply excessive force to, place heavy objects on, or pinch cables.  
There is a risk of failure, damage, or electric shock.
- Do not use the product in an environment that is subject to water, corrosive gases, or flammable gases, or near flammable materials.  
There is a risk of electric shock or fire.

## NOTICE

- Do not attempt to use a SERVOPACK or Servomotor that is damaged or that has missing parts.
- Install external emergency stop circuits that shut OFF the power supply and stops operation immediately when an error occurs.
- Select the brake power supply for a Servomotor with a Holding Brake according to the power supply voltage and capacity required for the Servomotor model, as given in manuals and catalogs. Also confirm the input voltage to the holding brake.
- Always install a surge absorber as a protective device between the brake power supply and Servomotor.  
There is a risk of damage to the Servomotor.
- The time required for a holding brake to operate depends on the types of protective devices. The time required for a holding brake to operate will also change if holding brakes are connected in parallel. Always check the time required for a holding brake to operate on the actual machine before you operate a Servomotor.
- Always use a Servomotor and SERVOPACK in one of the specified combinations.
- Do not touch a SERVOPACK or Servomotor with wet hands.  
There is a risk of product failure.

## ■ Storage Precautions



### CAUTION

- Do not place an excessive load on the product during storage. (Follow all instructions on the packages.)  
There is a risk of injury or damage.

### NOTICE

- Do not install or store the product in any of the following locations.
  - Locations that are subject to direct sunlight
  - Locations that are subject to ambient temperatures that exceed product specifications
  - Locations that are subject to relative humidities that exceed product specifications
  - Locations that are subject to condensation as the result of extreme changes in temperature
  - Locations that are subject to corrosive or flammable gases
  - Locations that are near flammable materials
  - Locations that are subject to dust, salts, or iron powder
  - Locations that are subject to water, oil, or chemicals
  - Locations that are subject to vibration or shock that exceeds product specifications
  - Locations that are subject to radiationIf you store or install the product in any of the above locations, the product may fail or be damaged.
- Although machined surfaces are covered with an anticorrosive coating, rust can develop due to storage conditions or the length of storage. If you store the product for more than six months, reapply an anticorrosive coating to machined surfaces, particularly the motor shaft.
- Consult with your Yaskawa representative if you have stored products for an extended period of time.

## ■ Transportation Precautions



### CAUTION

- Transport the product in a way that is suitable to the mass of the product.
- Do not hold onto the cables or motor shaft when you move a Servomotor.  
There is a risk of disconnection, damage, or injury.
- Make sure that the eyebolts are securely attached to the product with no looseness before you use them to move the product.  
There is a risk of injury or damage.
- Do not use the eyebolts on a SERVOPACK or Servomotor to move the machine.  
There is a risk of damage or injury.
- When you handle a SERVOPACK or Servomotor, be careful of sharp parts, such as the corners.  
There is a risk of injury.
- Do not place an excessive load on the product during transportation. (Follow all instructions on the packages.)  
There is a risk of injury or damage.

## NOTICE

- A SERVOPACK or Servomotor is a precision device. Do not drop it or subject it to strong shock. There is a risk of failure or damage.
- Do not subject connectors to shock. There is a risk of faulty connections or damage.
- If disinfectants or insecticides must be used to treat packing materials such as wooden frames, plywood, or pallets, the packing materials must be treated before the product is packaged, and methods other than fumigation must be used.  
Example: Heat treatment, where materials are kiln-dried to a core temperature of 56°C for 30 minutes or more.  
If the electronic products, which include stand-alone products and products installed in machines, are packed with fumigated wooden materials, the electrical components may be greatly damaged by the gases or fumes resulting from the fumigation process. In particular, disinfectants containing halogen, which includes chlorine, fluorine, bromine, or iodine can contribute to the erosion of the capacitors.
- Do not overtighten the eyebolts on a SERVOPACK or Servomotor. If you use a tool to overtighten the eyebolts, the tapped holes may be damaged.

### ■ Installation Precautions

## CAUTION

- Do not touch the key slot with your bare hands on the shaft end on a Servomotor with a Key Slot. There is a risk of injury.
- Securely mount the Servomotor to the machine. If the Servomotor is not mounted securely, it may come off the machine during operation.
- Install the Servomotor or SERVOPACK in a way that will support the mass given in technical documents.
- Install SERVOPACKs, Servomotors, regenerative resistors, and External Dynamic Brake Resistors on nonflammable materials. Installation directly onto or near flammable materials may result in fire.
- Do not step on or place a heavy object on the product. There is a risk of failure, damage, or injury.
- Do not allow any foreign matter to enter the SERVOPACK or Servomotor. There is a risk of failure or fire.
- Implement safety measures, such as installing a cover so that the rotating part of the Servomotor cannot be touched accidentally during operation.

## NOTICE

- Do not install or store the product in any of the following locations.
  - Locations that are subject to direct sunlight
  - Locations that are subject to ambient temperatures that exceed product specifications
  - Locations that are subject to relative humidities that exceed product specifications
  - Locations that are subject to condensation as the result of extreme changes in temperature
  - Locations that are subject to corrosive or flammable gases
  - Locations that are near flammable materials
  - Locations that are subject to dust, salts, or iron powder
  - Locations that are subject to water, oil, or chemicals
  - Locations that are subject to vibration or shock that exceeds product specifications
  - Locations that are subject to radiationIf you store or install the product in any of the above locations, the product may fail or be damaged.
- Use the product in an environment that is appropriate for the product specifications.  
If you use the product in an environment that exceeds product specifications, the product may fail or be damaged.
- A SERVOPACK or Servomotor is a precision device. Do not drop it or subject it to strong shock.  
There is a risk of failure or damage.
- A Servomotor is a precision device. Do not subject the output shaft or the main body of the Servomotor to strong shock.
- Design the machine so that the thrust and radial loads on the motor shaft during operation do not exceed the allowable values given in the catalog.
- When you attach the key to the motor shaft, do not subject the key slot to direct shock.
- Do not allow any foreign matter to enter a SERVOPACK or a Servomotor with a Cooling Fan and do not cover the outlet from the Servomotor's cooling fan.  
There is a risk of failure.
- If you use oil as the gear lubricant, always inject the specified oil before starting operation.
- You can install the Servomotor either horizontally or vertically. However, if you install a Servomotor with an Oil Seal with the output shaft facing upward, oil may enter the Servomotor depending on the operating conditions. Confirm the operating conditions sufficiently if you install a Servomotor with the output shaft facing upward. Some Servomotors with Gears have restrictions on the installation orientation. Refer to the relevant technical documents.
- If an installation orientation is specified for a Servomotor with a Gear, install the Servomotor in the specified orientation.  
There is a risk of failure due to oil leakage.
- For a Servomotor with an Oil Seal, use the Servomotor with the oil seal in a lubricated condition with only splashing of oil.  
If the Servomotor is used with the oil seal under the surface of the oil, oil may enter the Servomotor, possibly resulting in failure.
- The shaft opening of a Servomotor is not waterproof or oilproof. Implement measures in the machine to prevent water or cutting oil from entering the Servomotor.  
There is a risk of failure.
- In an application where the Servomotor would be subjected to large quantities of water or oil, implement measures to protect the Servomotor from large quantities of liquid, such as installing covers to protect against water and oil.
- In an environment with high humidity or oil mist, face Servomotor lead wires and connectors downward and provide cable traps.  
There is a risk of failure or fire due to insulation failure or accidents from short circuits.

### ■ Wiring Precautions



## DANGER

- Do not change any wiring while power is being supplied.  
There is a risk of electric shock or injury.



## WARNING

- **Wiring and inspections must be performed only by qualified engineers.**  
There is a risk of electric shock or product failure.
- **Check all wiring and power supplies carefully.**  
Incorrect wiring or incorrect voltage application to the output circuits may cause short-circuit failures. If a short-circuit failure occurs as a result of any of these causes, the holding brake will not work. This could damage the machine or cause an accident that may result in death or injury.



## CAUTION

- **Observe the precautions and instructions for wiring and trial operation precisely as described in this document.**  
Failures caused by incorrect wiring or incorrect voltage application in the brake circuit may cause the SERVOPACK to fail, damage the equipment, or cause an accident resulting in death or injury.
- **Check the wiring to be sure it has been performed correctly.**  
Connectors and pin layouts are sometimes different for different models. Always confirm the pin layouts in technical documents for your model before operation.  
There is a risk of failure or malfunction.
- **Connect wires to power supply terminals and motor connection terminals securely with the specified methods and tightening torque.**  
Insufficient tightening may cause wires and terminal blocks to generate heat due to faulty contact, possibly resulting in fire.
- **Use shielded twisted-pair cables or screened unshielded multi-twisted-pair cables for I/O Signal Cables and Encoder Cables.**
- **Observe the following precautions when wiring the SERVOPACK's main circuit terminals.**
  - Turn ON the power supply to the SERVOPACK only after all wiring, including the main circuit terminals, has been completed.
  - If a connector is used for the main circuit terminals, remove the main circuit connector from the SERVOPACK before you wire it.
  - Insert only one wire per insertion hole in the main circuit terminals.
  - When you insert a wire, make sure that the conductor wire (e.g., whiskers) does not come into contact with adjacent wires.

## NOTICE

- **Whenever possible, use the Cables specified by Yaskawa.**  
If you use any other cables, confirm the rated current and application environment of your model and use the wiring materials specified by Yaskawa or equivalent materials.
- **Securely tighten cable connector screws and lock mechanisms.**  
Insufficient tightening may result in cable connectors falling off during operation.
- **Do not bundle power lines (e.g., the Main Circuit Cable) and low-current lines (e.g., the I/O Signal Cables or Encoder Cables) together or run them through the same duct. If you do not place power lines and low-current lines in separate ducts, separate them by at least 30 cm.**  
If the cables are too close to each other, malfunctions may occur due to noise affecting the low-current lines.
- **For a motor with a cooling fan, check the rotation direction of the cooling fan after you wire the fan.**
- **Install a battery at either the host controller or on the Encoder Cable.**  
If you install batteries both at the host controller and on the Encoder Cable at the same time, you will create a loop circuit between the batteries, resulting in a risk of damage or burning.
- **When connecting a battery, connect the polarity correctly.**  
There is a risk of battery rupture or encoder failure.

## ■ Operation Precautions



### WARNING

- Before starting operation with a machine connected, change the settings of the switches and parameters to match the machine.  
Unexpected machine operation, failure, or personal injury may occur if operation is started before appropriate settings are made.
- Do not radically change the settings of the parameters.  
There is a risk of unstable operation, machine damage, or injury.
- Install limit switches or stoppers at the ends of the moving parts of the machine to prevent unexpected accidents.  
There is a risk of machine damage or injury.
- For trial operation, securely mount the Servomotor and disconnect it from the machine.  
There is a risk of injury.
- Forcing the motor to stop for overtravel is disabled when the Jog (Fn002), Origin Search (Fn003), or Easy FFT (Fn206) utility function is executed. Take necessary precautions.  
There is a risk of machine damage or injury.
- When an alarm occurs, the Servomotor will coast to a stop or stop with the dynamic brake according to the SERVOPACK Option and settings. The coasting distance will change with the moment of inertia of the load and the resistance of the External Dynamic Brake Resistor. Check the coasting distance during trial operation and implement suitable safety measures on the machine.
- Do not enter the machine's range of motion during operation.  
There is a risk of injury.
- Do not touch the moving parts of the Servomotor or machine during operation.  
There is a risk of injury.



### CAUTION

- Do not use the holding brake built into a Servomotor to stop the Servomotor. The holding brake is designed to hold the motor shaft. It is not designed as a stopping device to ensure machine safety. Provide an appropriate stopping device on the machine to ensure safety.  
There is a risk of brake failure due to wear, damage to the machine, or injury.
- Before you operate a Servomotor, supply power to the holding brake to release the holding brake. Refer to the timing charts in your Servomotor manual for details.
- During trial operation, confirm that the holding brake works correctly.
- When overtravel occurs, the power supply to the motor is turned OFF and the brake is released. If you use the Servomotor to drive a vertical load, set the Servomotor to enter a zero-clamped state after the Servomotor stops. Also, install safety devices (such as an external brake or counterweight) to prevent the moving parts of the machine from falling.
- Always turn OFF the servo before you turn OFF the power supply. If you turn OFF the main circuit power supply or control power supply during operation before you turn OFF the servo, the Servomotor will stop as follows:
  - If you turn OFF the main circuit power supply during operation without turning OFF the servo, the Servomotor will stop abruptly with the dynamic brake.
  - If you turn OFF the control power supply without turning OFF the servo, the stopping method that is used by the Servomotor depends on the model of the SERVOPACK. For details, refer to the manual for the SERVOPACK.

## NOTICE

- Always measure the vibration of the Servomotor with the Servomotor mounted to the machine and confirm that the vibration is within the allowable value.  
If the vibration is too large, the Servomotor will be damaged quickly and bolts may become loose.
- When you adjust the gain during system commissioning, use a measuring instrument to monitor the torque waveform and speed waveform and confirm that there is no vibration.  
If a high gain causes vibration, the Servomotor will be damaged quickly.
- An alarm or warning may occur if communications are performed with the host controller while the SigmaWin+ or Digital Operator is operating.  
If an alarm or warning occurs, it may interrupt the current process and stop the system.

### ■ Maintenance and Inspection Precautions



## DANGER

- Do not change any wiring while power is being supplied.  
There is a risk of electric shock or injury.



## WARNING

- Wiring and inspections must be performed only by qualified engineers.  
There is a risk of electric shock or product failure.
- If you replace a Servomotor with a Holding Brake, secure the machine before you replace the Servomotor.  
There is a risk of injury or equipment damage if the equipment falls.



## CAUTION

- Wait for six minutes after turning OFF the power supply and then make sure that the CHARGE indicator is not lit before starting wiring or inspection work. Do not touch the power supply terminals while the CHARGE lamp is lit after turning OFF the power supply because high voltage may still remain in the SERVOPACK.  
There is a risk of electric shock.
- Replace the Battery according to the correct procedure.  
If you remove the Battery or disconnect the Encoder Cable while the control power supply to the SERVOPACK is OFF, the absolute encoder data will be lost and position deviation may occur.

### ■ Troubleshooting Precautions



## DANGER

- If the safety device (molded-case circuit breaker or fuse) installed in the power supply line operates, remove the cause before you supply power to the SERVOPACK again. If necessary, repair or replace the SERVOPACK, check the wiring, and remove the factor that caused the safety device to operate.  
There is a risk of fire, electric shock, or injury.



## WARNING

- The product may suddenly start to operate when the power supply is recovered after a momentary power interruption. Design the machine to ensure human safety when operation restarts.  
There is a risk of injury.



## CAUTION

- When an alarm occurs, remove the cause of the alarm and ensure safety. Then reset the alarm or turn the power supply OFF and ON again to restart operation.  
There is a risk of injury or machine damage.
- If the Servo ON signal is input to the SERVOPACK and an alarm is reset, the Servomotor may suddenly restart operation. Confirm that the servo is OFF and ensure safety before you reset an alarm.  
There is a risk of injury or machine damage.
- The holding brake on a Servomotor will not ensure safety if there is the possibility that an external force (including gravity) may move the current position and create a hazardous situation when power is interrupted or an error occurs. If an external force may cause movement, install an external braking mechanism that ensures safety.

### ■ Disposal Precautions

- Correctly discard the product as stipulated by regional, local, and municipal laws and regulations. Be sure to include these contents in all labelling and warning notifications on the final product as necessary.



### ■ General Precautions

- Figures provided in this document are typical examples or conceptual representations. There may be differences between them and actual wiring, circuits, and products.
- The products shown in illustrations in this document are sometimes shown without covers or protective guards. Always replace all covers and protective guards before you use the product.
- If you need a new copy of this document because it has been lost or damaged, contact your nearest Yaskawa representative or one of the offices listed on the back of this document.
- This document is subject to change without notice for product improvements, specifications changes, and improvements to the manual itself.  
We will update the document number of the document and issue revisions when changes are made.
- Any and all quality guarantees provided by Yaskawa are null and void if the customer modifies the product in any way. Yaskawa disavows any responsibility for damages or losses that are caused by modified products.



---

# Warranty

## ◆ Details of Warranty

### ■ Warranty Period

The warranty period for a product that was purchased (hereinafter called the “delivered product”) is one year from the time of delivery to the location specified by the customer or 18 months from the time of shipment from the Yaskawa factory, whichever is sooner.

### ■ Warranty Scope

Yaskawa shall replace or repair a defective product free of charge if a defect attributable to Yaskawa occurs during the above warranty period.

This warranty does not cover defects caused by the delivered product reaching the end of its service life and replacement of parts that require replacement or that have a limited service life.

This warranty does not cover failures that result from any of the following causes.

- Improper handling, abuse, or use in unsuitable conditions or in environments not described in product catalogs or manuals, or in any separately agreed-upon specifications
- Causes not attributable to the delivered product itself
- Modifications or repairs not performed by Yaskawa
- Use of the delivered product in a manner in which it was not originally intended
- Causes that were not foreseeable with the scientific and technological understanding at the time of shipment from Yaskawa
- Events for which Yaskawa is not responsible, such as natural or human-made disasters

## ◆ Limitations of Liability

- Yaskawa shall in no event be responsible for any damage or loss of opportunity to the customer that arises due to failure of the delivered product.
- Yaskawa shall not be responsible for any programs (including parameter settings) or the results of program execution of the programs provided by the user or by a third party for use with programmable Yaskawa products.
- The information described in product catalogs or manuals is provided for the purpose of the customer purchasing the appropriate product for the intended application. The use thereof does not guarantee that there are no infringements of intellectual property rights or other proprietary rights of Yaskawa or third parties, nor does it construe a license.
- Yaskawa shall not be responsible for any damage arising from infringements of intellectual property rights or other proprietary rights of third parties as a result of using the information described in catalogs or manuals.

---

## ◆ Suitability for Use

- It is the customer's responsibility to confirm conformity with any standards, codes, or regulations that apply if the Yaskawa product is used in combination with any other products.
- The customer must confirm that the Yaskawa product is suitable for the systems, machines, and equipment used by the customer.
- Consult with Yaskawa to determine whether use in the following applications is acceptable. If use in the application is acceptable, use the product with extra allowance in ratings and specifications, and provide safety measures to minimize hazards in the event of failure.
  - Outdoor use, use involving potential chemical contamination or electrical interference, or use in conditions or environments not described in product catalogs or manuals
  - Nuclear energy control systems, combustion systems, railroad systems, aviation systems, vehicle systems, medical equipment, amusement machines, and installations subject to separate industry or government regulations
  - Systems, machines, and equipment that may present a risk to life or property
  - Systems that require a high degree of reliability, such as systems that supply gas, water, or electricity, or systems that operate continuously 24 hours a day
  - Other systems that require a similar high degree of safety
- Never use the product for an application involving serious risk to life or property without first ensuring that the system is designed to secure the required level of safety with risk warnings and redundancy, and that the Yaskawa product is properly rated and installed.
- The circuit examples and other application examples described in product catalogs and manuals are for reference. Check the functionality and safety of the actual devices and equipment to be used before using the product.
- Read and understand all use prohibitions and precautions, and operate the Yaskawa product correctly to prevent accidental harm to third parties.

## ◆ Specifications Change

The names, specifications, appearance, and accessories of products in product catalogs and manuals may be changed at any time based on improvements and other reasons. The next editions of the revised catalogs or manuals will be published with updated code numbers. Consult with your Yaskawa representative to confirm the actual specifications before purchasing a product.

## Compliance with UL Standards, EU Directives, UK Regulations and China Energy Efficiency Regulations

Certification marks for the standards for which the product has been certified by certification bodies are shown on nameplate. Products that do not have the marks are not certified for the standards. Refer to the SERVOPACK manual for compliant standards of SERVOPACKs.

### ◆ North American Safety Standards (UL)



Product	Model	North American Safety Standards (UL File No.)
Rotary Servomotors	<ul style="list-style-type: none"> <li>• SGM7A</li> <li>• SGM7J</li> <li>• SGM7G</li> </ul>	UL 1004-1 UL 1004-6 (E165827) CSA C22.2 No.100

### ◆ European Directives



Product	Model	European Directive	Harmonized Standards
Rotary Servomotors	<ul style="list-style-type: none"> <li>• SGM7J</li> <li>• SGM7A</li> <li>• SGM7G</li> </ul>	EMC Directive 2014/30/EU	EN 55011 group 1, class A EN 61000-6-2 EN 61000-6-4 EN 61800-3 (Category C2, Second environment)
		Low Voltage Directive 2014/35/EU	EN 60034-1 EN 60034-5
		RoHS Directive 2011/65/EU as amended by (EU)2015/863	EN IEC 63000

Note: 1. We declared the CE Marking based on the harmonized standards in the above table.

2. These products are for industrial use. In home environments, these products may cause electromagnetic interference and additional noise reduction measures may be necessary.

### ◆ UK Conformity Assessed (UKCA)



Product	Model	UK Regulations	Designated Standards
Rotary Servomotors	<ul style="list-style-type: none"> <li>• SGM7J</li> <li>• SGM7A</li> <li>• SGM7G</li> </ul>	Electromagnetic Compatibility Regulations S.I. 2016/1091	EN 55011 group 1, class A EN 61000-6-2 EN 61000-6-4 EN 61800-3 (Category C2, Second environment)
		Electrical Equipment (Safety) Regulations S.I. 2016/1101	EN 60034-1 EN 60034-5
		Restriction of the Use of Certain Hazardous Substances in Electrical and Electronic Equipment Regulations S.I. 2012/3032	EN IEC 63000

Note: 1. We declared the UKCA Marking based on the harmonized standards in the above table.

2. These products are for industrial use. In home environments, these products may cause electromagnetic interference and additional noise reduction measures may be necessary.

## ◆ China Energy Label for Permanent-Magnet Synchronous Motors



Product	Model	Application Range	Laws and Standards
Rotary Servomotors	<ul style="list-style-type: none"> <li>• SGM7J</li> <li>• SGM7A</li> <li>• SGM7G</li> </ul>	Rated Voltage 1000 V max.  Rated Output 0.55 kW ~ 90 kW  Rated Motor Speed 500 ~ 3000 min <sup>-1</sup>	law CEL 038-2020  regulation GB 30253-2013

Note: .The following products do not comply with the China Energy Label for permanent-magnet synchronous motors.

- Models with holding brakes
- Models with gears

# Contents

About this Manual . . . . .	iii
Outline of Manual . . . . .	iii
Related Documents . . . . .	iv
Using This Manual . . . . .	vii
Safety Precautions . . . . .	viii
Warranty . . . . .	xvii
Compliance with UL Standards, EU Directives, UK Regulations and China Energy Efficiency Regulations . . . . .	xix

## 1

### Basic Information on Servomotors

<b>1.1</b>	<b>Servomotor Part Names . . . . .</b>	<b>1-2</b>
<b>1.2</b>	<b>Interpreting the Nameplates . . . . .</b>	<b>1-3</b>
<b>1.3</b>	<b>Outline of Model Designations . . . . .</b>	<b>1-4</b>
1.3.1	Servomotor . . . . .	1-4
1.3.2	SERVOPACKs . . . . .	1-4
<b>1.4</b>	<b>Combinations of Servomotors and SERVOPACKs . . . . .</b>	<b>1-5</b>

## 2

### Capacity Selection

<b>2.1</b>	<b>Selecting the Servomotor Capacity . . . . .</b>	<b>2-2</b>
2.1.1	Capacity Selection Example for a Rotary Servomotor: For Speed Control . .	2-2
2.1.2	Capacity Selection Example for a Rotary Servomotor: For Position Control . .	2-4

## 3

### Specifications, Ratings, and External Dimensions of SGM7J Servomotors

<b>3.1</b>	<b>Model Designations . . . . .</b>	<b>3-2</b>
<b>3.2</b>	<b>Specifications and Ratings . . . . .</b>	<b>3-3</b>
3.2.1	Specifications . . . . .	3-3
3.2.2	Servomotor Ratings . . . . .	3-4
3.2.3	Motor Speed-Torque Characteristics . . . . .	3-5
3.2.4	Servomotor Overload Protection Characteristics . . . . .	3-6
3.2.5	Load Moment of Inertia . . . . .	3-6
3.2.6	Servomotor Heat Dissipation Conditions . . . . .	3-7
3.2.7	Applications Where the Surrounding Air Temperature of the Servomotor Exceeds 40°C . . . . .	3-7
3.2.8	Applications Where the Altitude of the Servomotor Exceeds 1,000 m . . . . .	3-8
<b>3.3</b>	<b>External Dimensions . . . . .</b>	<b>3-9</b>
3.3.1	Servomotors . . . . .	3-9
3.3.2	Shaft End Specifications . . . . .	3-12
3.3.3	Connector Specifications . . . . .	3-13

---

## 4

### Specifications, Ratings, and External Dimensions of SGM7A Servomotors

---

<b>4.1</b>	<b>Model Designations</b>	<b>4-2</b>
<b>4.2</b>	<b>Specifications and Ratings</b>	<b>4-3</b>
4.2.1	Specifications	4-3
4.2.2	Servomotor Ratings	4-4
4.2.3	Motor Speed-Torque Characteristics	4-6
4.2.4	Servomotor Overload Protection Characteristics	4-7
4.2.5	Load Moment of Inertia	4-7
4.2.6	Servomotor Heat Dissipation Conditions	4-8
4.2.7	Applications Where the Surrounding Air Temperature of the Servomotor Exceeds 40°C	4-9
4.2.8	Applications Where the Altitude of the Servomotor Exceeds 1,000 m	4-10
<b>4.3</b>	<b>External Dimensions</b>	<b>4-11</b>
4.3.1	Servomotors: SGM7A-02 to -10	4-11
4.3.2	Shaft End Specifications for SGM7A-02 to -10	4-14
4.3.3	Servomotors: SGM7A-15 to -70	4-15
4.3.4	Shaft End Specifications for SGM7A-15 to -70	4-18
4.3.5	Connector Specifications	4-19

## 5

### Specifications, Ratings, and External Dimensions of SGM7G Servomotors

---

<b>5.1</b>	<b>Model Designations</b>	<b>5-2</b>
<b>5.2</b>	<b>Specifications and Ratings</b>	<b>5-3</b>
5.2.1	Specifications	5-3
5.2.2	Servomotor Ratings	5-5
5.2.3	Motor Speed-Torque Characteristics	5-9
5.2.4	Servomotor Overload Protection Characteristics	5-11
5.2.5	Load Moment of Inertia	5-12
5.2.6	Servomotor Heat Dissipation Conditions	5-13
5.2.7	Servomotor Derating Rates for Surrounding Air Temperatures	5-13
5.2.8	Applications Where the Altitude of the Servomotor Exceeds 1,000 m	5-14
<b>5.3</b>	<b>External Dimensions</b>	<b>5-15</b>
5.3.1	Servomotors	5-15
5.3.2	Shaft End Specifications	5-19
5.3.3	Connector Specifications	5-20

## 6

### Servomotor Installation

---

<b>6.1</b>	<b>Installation Conditions</b>	<b>6-2</b>
6.1.1	Installation Precautions	6-2
6.1.2	Installation Environment	6-3
6.1.3	Installation Orientation	6-3
6.1.4	Using Servomotors with Holding Brakes	6-3
<b>6.2</b>	<b>Coupling to the Machine</b>	<b>6-4</b>
6.2.1	Using a Coupling	6-4
6.2.2	Using a Belt	6-5

<b>6.3</b>	<b>Oil and Water Countermeasures . . . . .</b>	<b>6-7</b>
<b>6.4</b>	<b>Servomotor Temperature Increase . . . . .</b>	<b>6-8</b>

## **7** Connections between Servomotors and SERVOPACKs

<b>7.1</b>	<b>Wiring Servomotors and SERVOPACKs . . . . .</b>	<b>7-2</b>
7.1.1	Wiring Precautions . . . . .	7-2

## **8** Maintenance and Inspection

<b>8.1</b>	<b>Periodic Inspections . . . . .</b>	<b>8-2</b>
<b>8.2</b>	<b>Service Lives of Parts . . . . .</b>	<b>8-3</b>
<b>8.3</b>	<b>Disposing of Servomotors . . . . .</b>	<b>8-4</b>

## **9** Appendices

<b>9.1</b>	<b>Reference Information for Servomotor Capacity Selection . . . . .</b>	<b>9-2</b>
9.1.1	Formulas Required to Select the Servomotor Capacity . . . . .	9-2
9.1.2	GD <sup>2</sup> for Simple Diagrams . . . . .	9-3
9.1.3	Conversions between Engineering Units and SI Units . . . . .	9-4
9.1.4	Application Examples by Type of Application . . . . .	9-5

### **Revision History**

# Basic Information on Servomotors

---

# 1

This chapter provides basic information on Rotary Servomotors, including Servomotor part names and combinations with SERVOPACKs.

<b>1.1</b>	<b>Servomotor Part Names</b> . . . . .	<b>1-2</b>
<b>1.2</b>	<b>Interpreting the Nameplates</b> . . . . .	<b>1-3</b>
<b>1.3</b>	<b>Outline of Model Designations</b> . . . . .	<b>1-4</b>
1.3.1	Servomotor . . . . .	1-4
1.3.2	SERVOPACKs . . . . .	1-4
<b>1.4</b>	<b>Combinations of Servomotors and SERVOPACKs</b> . .	<b>1-5</b>



# 1.1 Servomotor Part Names

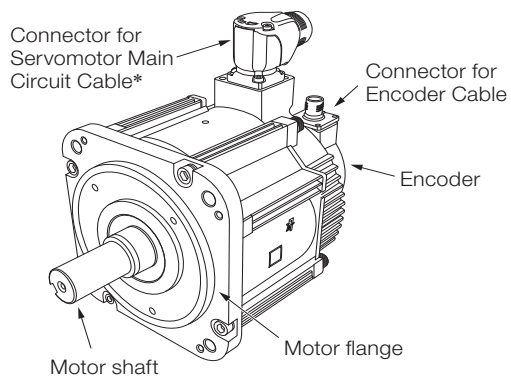

\* This connector is also used to connect the holding brake for a Servomotor with a Holding Brake.

## 1.2 Interpreting the Nameplates

The following basic information is provided on the nameplate.

The nameplate is printed on the Servomotor.

The layout of the nameplate depends somewhat on the model of the Servomotor.

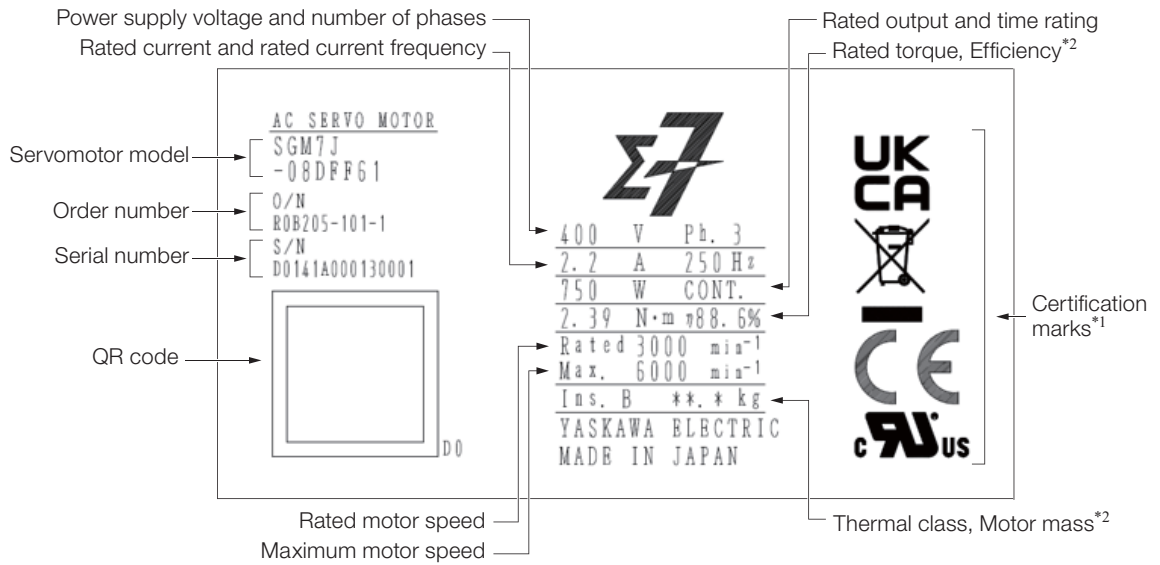

\*1. Certification marks for the standards for which the Servomotor has been certified by certification bodies are shown on the product.

\*2. These values are displayed only when required by the standards.

# 1.3 Outline of Model Designations

## 1.3.1 Servomotor

This section outlines the model numbers of  $\Sigma$ -7-Series Servomotors. For details, refer to the chapter for your type of Servomotor.



Series  $\Sigma$ -7-Series Servomotors

Code	Specifications	Reference
SGM7J	Medium inertia, high speed	Chapter 3
SGM7A	Low inertia, high speed	Chapter 4
SGM7G	Medium inertia, low speed, high torque	Chapter 5
	Medium inertia, high speed, high torque	

1st+2nd digits Rated Output

- SGM7J: 200 W to 1.5 kW
- SGM7A: 200 W to 7.0 kW
- SGM7G: 450 W to 15 kW

3rd digit Power Supply Voltage

- 400 VAC

4th digit Serial Encoder Specification

- 24-bit absolute
- 24-bit incremental

5th digit Design Revision Order

6th digit Shaft End Specification

- Straight without key
- Straight with key and tap

7th digit Options

- With holding brake
- With dust seal

## 1.3.2 SERVOPACKs

This section outlines the model numbers of  $\Sigma$ -7-Series SERVOPACKs. Refer to the following manuals for details.

📖  $\Sigma$ -7-Series  $\Sigma$ -7S SERVOPACK with 400-V Input Power and EtherCAT (CoE) Communications References Product Manual (Manual No.: SIEP S800001 80)

📖  $\Sigma$ -7-Series  $\Sigma$ -7S SERVOPACK with 400 V-Input Power and MECHATROLINK-III Communications References RJ-45 Connectors Product Manual (Manual No.: SIEP S800002 14)

📖  $\Sigma$ -7-Series  $\Sigma$ -7W SERVOPACK with 400-V Input Power and EtherCAT (CoE) Communications References Product Manual (Manual No.: SIEP S800002 19)

📖  $\Sigma$ -7-Series  $\Sigma$ -7W SERVOPACK with 400 V-Input Power and MECHATROLINK-III Communications References RJ-45 Connectors Product Manual (Manual No.: SIEP S800002 20)



Series  $\Sigma$ -7-Series SERVOPACKs

Code	Specification
SGD7S	Single-axis SERVOPACKs
SGD7W	Two-axis SERVOPACKs

1st+2nd+3rd digits Maximum Applicable Motor Capacity

- SGD7S: 0.5 kW to 5.0 kW
- SGD7W: 0.75 kW or 1.5 kW

4th digit Power Supply Voltage

- 400 VAC

5th+6th digits Interface

- EtherCAT communications references
- MECHATROLINK-III communications references and RJ-45 connectors

7th digit Design Revision Order

8th+9th+10th digits Hardware Options Specification

- Built-in Servomotor brake control

11th+12th+13th digits FT/EX Specification\*

- ZONE outputs

\* Not supported by the SGD7W.

## 1.4

## Combinations of Servomotors and SERVOPACKs

Rotary Servomotor Model		Capacity	SERVOPACK Model	
			SGD7S-	SGD7W-
SGM7J Models (Medium Inertia, High Speed), Rated motor speed: 3,000 min <sup>-1</sup>	SGM7J-02D□F	200 W	1R9D	2R6D*
	SGM7J-04D□F	400 W		2R6D* or 5R4D*
	SGM7J-08D□F	750 W		2R6D or 5R4D*
	SGM7J-15D□F	1.5 kW		5R4D
SGM7A Models (Low Inertia, High Speed), Rated motor speed: 3,000 min <sup>-1</sup>	SGM7A-02D□F	200 W	1R9D	2R6D*
	SGM7A-04D□F	400 W		2R6D* or 5R4D*
	SGM7A-08D□F	750 W		2R6D or 5R4D*
	SGM7A-10D□F	1.0 kW	5R4D	5R4D*
	SGM7A-15D□F	1.5 kW		5R4D
	SGM7A-20D□F	2.0 kW	8R4D	-
	SGM7A-25D□F	2.5 kW	120D	
	SGM7A-30D□F	3.0 kW		
	SGM7A-40D□F	4.0 kW	170D	
	SGM7A-50D□F	5.0 kW		
SGM7A-70D□F	7.0 kW	260D		
SGM7G Models Standard Models (Medium Inertia, Low Speed, High Torque), Rated motor speed: 1,500 min <sup>-1</sup>	SGM7G-05D□F	450 W	1R9D	
	SGM7G-09D□F	850 W	3R5D	5R4D*
	SGM7G-13D□F	1.3 kW	5R4D	5R4D
	SGM7G-20D□F	1.8 kW	8R4D	-
	SGM7G-30D□F	2.9 kW	120D	
	SGM7G-44D□F	4.4 kW	170D	
	SGM7G-55D□F	5.5 kW	210D	
	SGM7G-75D□F	7.5 kW	260D	
	SGM7G-1AD□F	11 kW	280D	
SGM7G-1ED□F	15 kW	370D		
SGM7G Models High-speed Models (Medium Inertia, High Speed, High Torque) Rated motor speed: 1,500 min <sup>-1</sup>	SGM7G-05D□R	450 W	3R5D	2R6D or 5R4D*
	SGM7G-09D□R	850 W	5R4D	5R4D
	SGM7G-13D□R	1.3 kW	8R4D	-
	SGM7G-20D□R	1.8 kW	120D	
	SGM7G-30D□R	2.9 kW	170D	
	SGM7G-44D□R	4.4 kW	210D	

\* If you use this combination, performance may not be as good, e.g., the control gain may not increase, in comparison with using a Σ-7S SERVOPACK.

# Capacity Selection

---

# 2

This chapter describes calculation methods to use when selecting Servomotor capacities.

## **2.1** Selecting the Servomotor Capacity . . . . . 2-2

- 2.1.1 Capacity Selection Example for a Rotary Servomotor: For Speed Control . . . . . 2-2
- 2.1.2 Capacity Selection Example for a Rotary Servomotor: For Position Control . . . . . 2-4

# 2.1 Selecting the Servomotor Capacity

Refer to the following selection examples to select Servomotor capacities with manual calculations rather than with the above software.

## 2.1.1 Capacity Selection Example for a Rotary Servomotor: For Speed Control

### 1. Mechanical Specifications

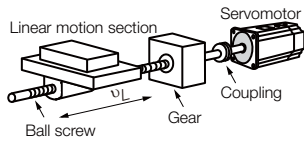

Item	Code	Value
Load Speed	$v_L$	15 m/min
Linear Motion Section Mass	$m$	250 kg
Ball Screw Length	$l_B$	1.0 m
Ball Screw Diameter	$d_B$	0.02 m
Ball Screw Lead	$P_B$	0.01 m
Ball Screw Material Density	$\rho$	$7.87 \times 10^3 \text{ kg/m}^3$
Gear Ratio	$R$	2 (gear ratio: 1/2)
External Force on Linear Motion Section	$F$	0 N

Item	Code	Value
Gear and Coupling Moment of Inertia	$J_G$	$0.40 \times 10^{-4} \text{ kg}\cdot\text{m}^2$
Number of Feeding Operations	$n$	40 rotations/min
Feeding Distance	$l$	0.275 m
Feeding Time	$tm$	1.2 s max.
Friction Coefficient	$\mu$	0.2
Mechanical Efficiency	$\eta$	0.9 (90%)

### 2. Operation Pattern

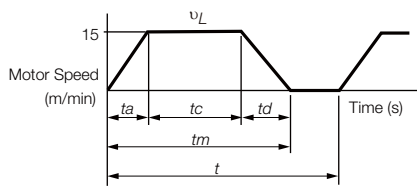

$$t = \frac{60}{n} = \frac{60}{40} = 1.5 \text{ (s)}$$

If  $t_a = t_d$ ,

$$t_a = t_m - \frac{60 \cdot l}{v_L} = 1.2 - \frac{60 \times 0.275}{15} = 1.2 - 1.1 = 0.1 \text{ (s)}$$

$$t_c = 1.2 - 0.1 \times 2 = 1.0 \text{ (s)}$$

### 3. Motor Speed

- Load shaft speed  $n_L = \frac{v_L}{P_B} = \frac{15}{0.01} = 1,500 \text{ (min}^{-1}\text{)}$
- Motor shaft speed  $n_M = n_L \cdot R = 1,500 \times 2 = 3,000 \text{ (min}^{-1}\text{)}$

### 4. Load Torque

$$T_L = \frac{(9.8 \cdot \mu \cdot m + F) \cdot P_B}{2\pi R \cdot \eta} = \frac{(9.8 \times 0.2 \times 250 + 0) \times 0.01}{2\pi \times 2 \times 0.9} = 0.43 \text{ (N}\cdot\text{m)}$$

**5. Load Moment of Inertia**

- Linear motion section

$$J_{L1} = m \left( \frac{P_B}{2\pi R} \right)^2 = 250 \times \left( \frac{0.01}{2\pi \times 2} \right)^2 = 1.58 \times 10^{-4} \text{ (kg}\cdot\text{m}^2\text{)}$$

- Ball screw

$$J_B = \frac{\pi}{32} \rho \cdot \ell_B \cdot d_B^4 \cdot \frac{1}{R^2} = \frac{\pi}{32} \times 7.87 \times 10^3 \times 1.0 \times (0.02)^4 \cdot \frac{1}{2^2} = 0.31 \times 10^{-4} \text{ (kg}\cdot\text{m}^2\text{)}$$

- Coupling  $J_G = 0.40 \times 10^{-4} \text{ (kg}\cdot\text{m}^2\text{)}$
- Load moment of inertia at motor shaft

$$J_L = J_{L1} + J_B + J_G = (1.58 + 0.31 + 0.40) \times 10^{-4} = 2.29 \times 10^{-4} \text{ (kg}\cdot\text{m}^2\text{)}$$

**6. Load Moving Power**

$$P_O = \frac{2\pi n_M \cdot T_L}{60} = \frac{2\pi \times 3,000 \times 0.43}{60} = 135 \text{ (W)}$$

**7. Load Acceleration Power**

$$P_a = \left( \frac{2\pi}{60} n_M \right)^2 \frac{J_L}{t_a} = \left( \frac{2\pi}{60} \times 3,000 \right)^2 \times \frac{2.29 \times 10^{-4}}{0.1} = 226 \text{ (W)}$$

**8. Servomotor Provisional Selection****① Selection Conditions**

- $T_L \leq$  Motor rated torque
- $\frac{(P_O + P_a)}{2} <$  Provisionally selected Servomotor rated output  $< (P_O + P_a)$
- $n_M \leq$  Rated motor speed
- $J_L \leq$  Allowable load moment of inertia

The following Servomotor meets the selection conditions.

- SGM7J-02D Servomotor

**② Specifications of the Provisionally Selected Servomotor**

Item	Value
Rated Output	200 (W)
Rated Motor Speed	3,000 ( $\text{min}^{-1}$ )
Rated Torque	0.637 (N·m)
Instantaneous Maximum Torque	2.23 (N·m)
Motor Moment of Inertia	$0.263 \times 10^{-4} \text{ (kg}\cdot\text{m}^2\text{)}$
Allowable Load Moment of Inertia	$0.263 \times 10^{-4} \times 15 = 3.94 \times 10^{-4} \text{ (kg}\cdot\text{m}^2\text{)}$

**9. Verification of the Provisionally Selected Servomotor**

- Verification of required acceleration torque:

$$T_P = \frac{2\pi n_M (J_M + J_L)}{60 t_a} + T_L = \frac{2\pi \times 3,000 \times (0.263 + 2.29) \times 10^{-4}}{60 \times 0.1} + 0.43$$

$$\approx 1.23 \text{ (N}\cdot\text{m)} < \text{Maximum instantaneous torque...Satisfactory}$$

- Verification of required deceleration torque:

$$T_S = \frac{2\pi n_M (J_M + J_L)}{60 t_d} - T_L = \frac{2\pi \times 3,000 \times (0.263 + 2.29) \times 10^{-4}}{60 \times 0.1} - 0.43$$

$$\approx 0.37 \text{ (N}\cdot\text{m)} < \text{Maximum instantaneous torque...Satisfactory}$$

2.1 Selecting the Servomotor Capacity

2.1.2 Capacity Selection Example for a Rotary Servomotor: For Position Control

- Verification of effective torque value:

$$T_{rms} = \sqrt{\frac{T_P^2 \cdot ta + T_L^2 \cdot tc + T_s^2 \cdot td}{t}} = \sqrt{\frac{(1.23)^2 \times 0.1 + (0.43)^2 \times 1.0 + (0.37)^2 \times 0.1}{1.5}}$$

$$\approx 0.483 \text{ (N}\cdot\text{m)} < \text{Rated torque...Satisfactory}$$

10. Result

It has been verified that the provisionally selected Servomotor is applicable. The torque diagram is shown below.

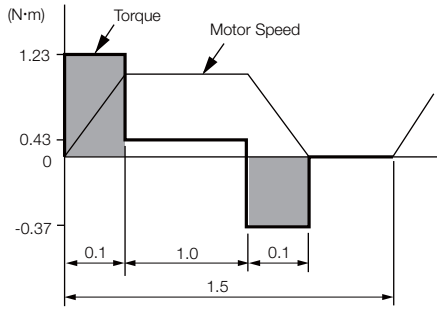

2.1.2 Capacity Selection Example for a Rotary Servomotor: For Position Control

1. Mechanical Specifications

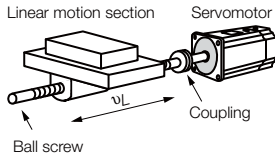

Item	Code	Value
Load Speed	$v_L$	15 m/min
Linear Motion Section Mass	$m$	80 kg
Ball Screw Length	$\ell_B$	0.8 m
Ball Screw Diameter	$d_B$	0.016 m
Ball Screw Lead	$P_B$	0.005 m
Ball Screw Material Density	$\rho$	$7.87 \times 10^3 \text{ kg/m}^3$
External Force on Linear Motion Section	$F$	0 N
Coupling Mass	$m_C$	0.3 kg

Item	Code	Value
Coupling Outer Diameter	$d_C$	0.03 m
Number of Feeding Operations	$n$	40 rotation/min
Feeding Distance	$\ell$	0.25 m
Feeding Time	$tm$	1.2 s max.
Electrical Stopping Precision	$\delta$	$\pm 0.01 \text{ mm}$
Friction Coefficient	$\mu$	0.2
Mechanical Efficiency	$\eta$	0.9 (90%)

2. Speed Diagram

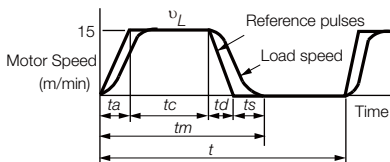

$$t = \frac{60}{n} = \frac{60}{40} = 1.5 \text{ (s)}$$

If  $t_a = t_d$  and  $t_s = 0.1 \text{ (s)}$ ,

$$t_a = t_m - t_s - \frac{60 \ell}{v_L} = 1.2 - 0.1 - \frac{60 \times 0.25}{15} = 0.1 \text{ (s)}$$

$$t_c = 1.2 - 0.1 - 0.1 \times 2 = 0.9 \text{ (s)}$$



**3. Motor Speed**

- Load shaft speed  $n_L = \frac{v_L}{P_B} = \frac{15}{0.005} = 3,000 \text{ (min}^{-1}\text{)}$
- Motor shaft speed Direct coupling gear ratio  $1/R = 1/1$   
Therefore,  $n_M = n_L \cdot R = 3,000 \times 1 = 3,000 \text{ (min}^{-1}\text{)}$

**4. Load Torque**

$$T_L = \frac{(9.8 \mu \cdot m + F) \cdot P_B}{2\pi R \cdot \eta} = \frac{(9.8 \times 0.2 \times 80 + 0) \times 0.005}{2\pi \times 1 \times 0.9} = 0.139 \text{ (N}\cdot\text{m)}$$

**5. Load Moment of Inertia**

- Linear motion section

$$J_{L1} = m \left( \frac{P_B}{2\pi R} \right)^2 = 80 \times \left( \frac{0.005}{2\pi \times 1} \right)^2 = 0.507 \times 10^{-4} \text{ (kg}\cdot\text{m}^2\text{)}$$

- Ball screw  $J_B = \frac{\pi}{32} \rho \cdot l_B \cdot d_B^4 = \frac{\pi}{32} \times 7.87 \times 10^3 \times 0.8 \times (0.016)^4 = 0.405 \times 10^{-4} \text{ (kg}\cdot\text{m}^2\text{)}$

- Coupling  $J_C = \frac{1}{8} m_C \cdot d_C^2 = \frac{1}{8} \times 0.3 \times (0.03)^2 = 0.338 \times 10^{-4} \text{ (kg}\cdot\text{m}^2\text{)}$

- Load moment of inertia at motor shaft

$$J_L = J_{L1} + J_B + J_C = 1.25 \times 10^{-4} \text{ (kg}\cdot\text{m}^2\text{)}$$

**6. Load Moving Power**

$$P_O = \frac{2\pi n_M \cdot T_L}{60} = \frac{2\pi \times 3,000 \times 0.139}{60} = 43.7 \text{ (W)}$$

**7. Load Acceleration Power**

$$P_a = \left( \frac{2\pi}{60} n_M \right)^2 \frac{J_L}{t_a} = \left( \frac{2\pi}{60} \times 3,000 \right)^2 \times \frac{1.25 \times 10^{-4}}{0.1} = 123.4 \text{ (W)}$$

**8. Servomotor Provisional Selection**

① Selection Conditions

- $T_L \leq$  Motor rated torque
- $\frac{(P_O + P_a)}{2} <$  Provisionally selected Servomotor rated output  $< (P_O + P_a)$
- $n_M \leq$  Rated motor speed
- $J_L \leq$  Allowable load moment of inertia

The following Servomotor meets the selection conditions.

- SGM7J-02D Servomotor

② Specifications of the Provisionally Selected Servomotor

Item	Value
Rated Output	200 (W)
Rated Motor Speed	3,000 (min <sup>-1</sup> )
Rated Torque	0.637 (N·m)
Instantaneous Maximum Torque	2.23 (N·m)
Motor Moment of Inertia	0.263 × 10 <sup>-4</sup> (kg·m <sup>2</sup> )
Allowable Load Moment of Inertia	0.263 × 10 <sup>-4</sup> × 15 = 3.94 × 10 <sup>-4</sup> (kg·m <sup>2</sup> )
Encoder Resolution	16,777,216 (pulses/rev) (24 bits)

**9. Verification of the Provisionally Selected Servomotor**

- Verification of required acceleration torque:

$$T_P = \frac{2\pi n_M (J_M + J_L)}{60ta} + T_L = \frac{2\pi \times 3,000 \times (0.263 + 1.25) \times 10^{-4}}{60 \times 0.1} + 0.139$$

$$\approx 0.614 \text{ (N}\cdot\text{m)} < \text{Maximum instantaneous torque...Satisfactory}$$

- Verification of required deceleration torque:

$$T_S = \frac{2\pi n_M (J_M + J_L)}{60td} - T_L = \frac{2\pi \times 3,000 \times (0.263 + 1.25) \times 10^{-4}}{60 \times 0.1} - 0.139$$

$$\approx 0.336 \text{ (N}\cdot\text{m)} < \text{Maximum instantaneous torque...Satisfactory}$$

- Verification of effective torque value:

$$T_{rms} = \sqrt{\frac{T_P^2 \cdot ta + T_L^2 \cdot tc + T_S^2 \cdot td}{t}} = \sqrt{\frac{(0.614)^2 \times 0.1 + (0.139)^2 \times 0.9 + (0.336)^2 \times 0.1}{1.5}}$$

$$\approx 0.210 \text{ (N}\cdot\text{m)} < \text{Rated torque...Satisfactory}$$

It has been verified that the provisionally selected Servomotor is applicable in terms of capacity. Position control is considered next.

**10. Positioning Resolution**

The electrical stopping precision  $\delta$  is  $\pm 0.01$  mm, so the positioning resolution  $\Delta_\ell$  is 0.01 mm.

The ball screw lead  $P_B$  is 0.005 m, so the number of pulses per motor rotation is calculated with the following formula.

$$\text{Number of pulses per rotation (pulses)} = \frac{P_B}{\Delta_\ell} = \frac{5 \text{ mm/rev}}{0.01 \text{ mm}} = 500 \text{ (P/rev)} < \text{Encoder resolution (16,777,216 (pulses/rev))}$$

The number of pulses per motor rotation is less than the encoder resolution (pulses/rev), so the provisionally selected motor can be used.

**11. Reference Pulse Frequency**

The load speed  $v_L$  is 15 m/min, or  $1,000 \times 15/60$  mm/s and the positioning resolution (travel distance per pulse) is 0.01 mm/pulse, so the reference pulse frequency is calculated with the following formula.

$$v_s = \frac{1,000 v_L}{60 \times \Delta_\ell} = \frac{1,000 \times 15}{60 \times 0.01} = 25,000 \text{ (pps)}$$

The reference pulse frequency is less than the maximum input pulse frequency,\* so the provisionally selected Servomotor can be used.

\*Refer to the specifications in the SERVOPACK manual for the maximum input pulse frequency.

It has been verified that the provisionally selected Servomotor is applicable for position control.

# Specifications, Ratings, and External Dimensions of SGM7J Servomotors

# 3

This chapter describes how to interpret the model numbers of SGM7J Servomotors and gives their specifications, ratings, and external dimensions.

<b>3.1</b>	<b>Model Designations</b> .....	<b>3-2</b>
<b>3.2</b>	<b>Specifications and Ratings</b> .....	<b>3-3</b>
3.2.1	Specifications .....	3-3
3.2.2	Servomotor Ratings .....	3-4
3.2.3	Motor Speed-Torque Characteristics .....	3-5
3.2.4	Servomotor Overload Protection Characteristics	3-6
3.2.5	Load Moment of Inertia .....	3-6
3.2.6	Servomotor Heat Dissipation Conditions .....	3-7
3.2.7	Applications Where the Surrounding Air Temperature of the Servomotor Exceeds 40°C ..	3-7
3.2.8	Applications Where the Altitude of the Servomotor Exceeds 1,000 m .....	3-8
<b>3.3</b>	<b>External Dimensions</b> .....	<b>3-9</b>
3.3.1	Servomotors .....	3-9
3.3.2	Shaft End Specifications .....	3-12
3.3.3	Connector Specifications .....	3-13

# 3.1 Model Designations

SGM7J - 02 D 7 F 2 1

1st+2nd digits
3rd digit
4th digit
5th digit
6th digit
7th digit

Σ-7 Series  
Servomotors:  
SGM7J

**1st+2nd digits** Rated Output

Code	Specification
02	200 W
04	400 W
08	750 W
15	1.5 kW

**3rd digit** Power Supply Voltage

Code	Specification
D	400 VAC

**4th digit** Serial Encoder

Code	Specification
7	24-bit absolute
F	24-bit incremental

**5th digit** Design Revision Order

F

**6th digit** Shaft End

Code	Specification
2	Straight without key
6	Straight with key and tap

**7th digit** Options

Code	Specification
1	Without options
C	With holding brake (24 VDC)

## 3.2 Specifications and Ratings

### 3.2.1 Specifications

Voltage		400 V			
Model SGM7J-		02D	04D	08D	15D
Time Rating		Continuous			
Thermal Class		B			
Insulation Resistance		500 VDC, 10 M $\Omega$ min.			
Withstand Voltage		1,800 VAC for 1 minute			
Excitation		Permanent magnet			
Mounting		Flange-mounted			
Drive Method		Direct drive			
Rotation Direction		Counterclockwise (CCW) for forward reference when viewed from the load side			
Vibration Class*1		V15			
Environmental Conditions	Surrounding Air Temperature	0°C to 40°C (With derating, usage is possible between 40°C and 60°C.)*4			
	Surrounding Air Humidity	20% to 80% relative humidity (with no condensation)			
	Installation Site	<ul style="list-style-type: none"> <li>• Must be indoors and free of corrosive and explosive gases.</li> <li>• Must be well-ventilated and free of dust and moisture.</li> <li>• Must facilitate inspection and cleaning.</li> <li>• Must have an altitude of 1,000 m or less. (With derating, usage is possible between 1,000 m and 2,000 m.)*5</li> <li>• Must be free of strong magnetic fields.</li> </ul>			
	Storage Environment	Store the Servomotor in the following environment if you store it with the power cable disconnected. Storage temperature: -20°C to 60°C (with no freezing) Storage humidity: 20% to 80% relative humidity (with no condensation)			
Shock Resistance*2	Impact Acceleration Rate at Flange	490 m/s <sup>2</sup>			
	Number of Impacts	2 times			
Vibration Resistance*3	Vibration Acceleration Rate at Flange	49 m/s <sup>2</sup>			
Applicable SERVOPACKs	SGD7S-	1R9D		3R5D	5R4D
	SGD7W-	2R6D*6	2R6D*6 or 5R4D*6	2R6D or 5R4D*6	5R4D

\*1. A vibration class of V15 indicates a vibration amplitude of 15  $\mu$ m maximum on the Servomotor without a load at the rated motor speed.

\*2. The shock resistance for shock in the vertical direction when the Servomotor is mounted with the shaft in a horizontal position is given in the above table.

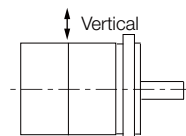

Shock Applied to the Servomotor

\*3. The vertical, side-to-side, and front-to-back vibration resistance for vibration in three directions when the Servomotor is mounted with the shaft in a horizontal position is given in the above table. The strength of the vibration that the Servomotor can withstand depends on the application. Always check the vibration acceleration rate that is applied to the Servomotor with the actual equipment.

## 3.2 Specifications and Ratings

### 3.2.2 Servomotor Ratings

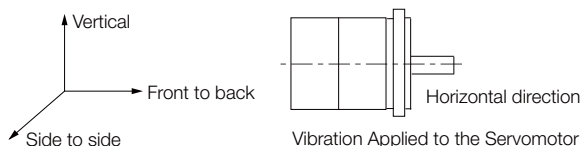

\*4. If the surrounding air temperature will exceed 40°C, refer to the following section.

**3.2.7 Applications Where the Surrounding Air Temperature of the Servomotor Exceeds 40 °C on page 3-7**

\*5. If the altitude will exceed 1,000 m, refer to the following section.

**3.2.8 Applications Where the Altitude of the Servomotor Exceeds 1,000 m on page 3-8**

\*6. If you use this combination, performance may not be as good, e.g., the control gain may not increase, in comparison with using a  $\Sigma$ -7S SERVOPACK.

## 3.2.2 Servomotor Ratings

Voltage		400 V				
Model SGM7J-		02D	04D	08D	15D	
Rated Output* <sup>1</sup>	W	200	400	750	1500	
Rated Torque* <sup>1, *2</sup>	N·m	0.637	1.27	2.39	4.77	
Instantaneous Maximum Torque* <sup>1</sup>	N·m	2.23	4.46	8.36	14.3	
Rated Current* <sup>1</sup>	Arms	1.5	1.4	2.2	4.5	
Instantaneous Maximum Current* <sup>1</sup>	Arms	5.5	5.3	8.2	14.0	
Rated Motor Speed* <sup>1</sup>	min <sup>-1</sup>	3000				
Maximum Motor Speed* <sup>1</sup>	min <sup>-1</sup>	6000				
Torque Constant	N·m/Arms	0.461	0.965	1.17	1.13	
Motor Moment of Inertia	$\times 10^{-4}$ kg·m <sup>2</sup>	0.263 (0.333)	0.486 (0.556)	1.59 (1.77)	4.02 (4.90)	
Rated Power Rate* <sup>1</sup>	kW/s	15.4 (12.1)	33.1 (29.0)	35.9 (32.2)	56.6 (46.4)	
Rated Angular Acceleration Rate* <sup>1</sup>	rad/s <sup>2</sup>	24200 (19100)	26100 (22800)	15000 (13500)	11900 (9700)	
Heat Sink Size (aluminum)	mm	250 × 250 × 6			300 × 300 × 12	
Protective Structure* <sup>3</sup>		Totally enclosed, self-cooled, IP67				
Holding Brake Specifications* <sup>4</sup>	Rated Voltage	V	24 VDC $\pm$ 10%			
	Capacity	W	6	6.5	7.5	
	Holding Torque	N·m	0.637	1.27	2.39	4.77
	Coil Resistance	$\Omega$ (at 20°C)	96 $\pm$ 10%		88.6 $\pm$ 10%	76.8 $\pm$ 10%
	Rated Current	A (at 20°C)	0.25		0.27	0.31
	Time Required to Release Brake	ms	60		80	
	Time Required to Brake	ms	100			
Allowable Load Moment of Inertia (Motor Moment of Inertia Ratio)* <sup>5</sup>	Standard	15 times	10 times	12 times	6 times	
	With External Regenerative Resistor or Dynamic Brake Resistor Connected	25 times		15 times	12 times	
Allowable Shaft Loads* <sup>6</sup>	LF	mm	25		35	
	Allowable Radial Load	N	245		392	490
	Allowable Thrust Load	N	74		147	

Note: The values in parentheses are for Servomotors with Holding Brakes.

\*1. These values are for operation in combination with a SERVOPACK when the temperature of the armature winding is 100°C. The values for other items are at 20°C. These are typical values.

- \*2. The rated torques are the continuous allowable torque values at a surrounding air temperature of 40°C with an aluminum heat sink of the dimensions given in the table.
- \*3. This does not apply to the shaft opening. Protective structure specifications apply only when the special cable is used.
- \*4. Observe the following precautions if you use a Servomotor with a Holding Brake.
  - The holding brake cannot be used to stop the Servomotor.
  - The time required to release the brake and the time required to brake depend on which discharge circuit is used. Confirm that the operation delay time is appropriate for the actual equipment.
  - The 24-VDC power supply is not provided by Yaskawa.
- \*5. The motor moment of inertia scaling factor is the value for a standard Servomotor without a Holding Brake.
- \*6. The allowable shaft loads are illustrated in the following figure. Design the mechanical system so that the thrust and radial loads applied to the Servomotor shaft end during operation do not exceed the values given in the table.

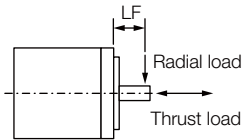

## 3.2.3 Motor Speed-Torque Characteristics

- [A] : Continuous duty zone
- [B] : Intermittent duty zone

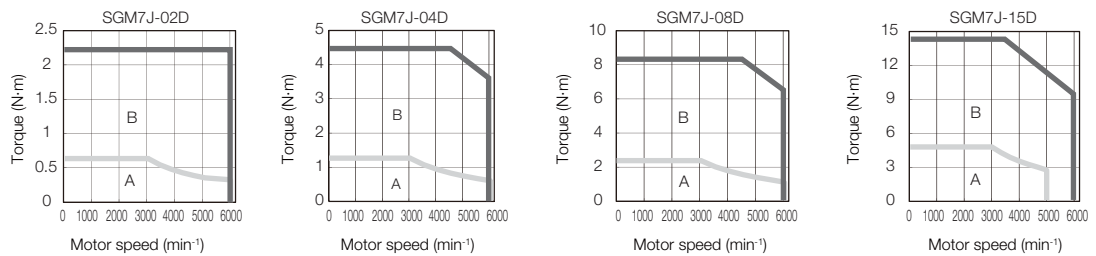

- Note: 1. These values are for operation in combination with a SERVOPACK when the temperature of the armature winding is 100°C. These are typical values.
2. The characteristics in the intermittent duty zone depend on the power supply voltage. The intermittent duty zones in the graphs show the characteristics when a three-phase, 400-VAC power supply voltage is used.
3. If the effective torque is within the allowable range for the rated torque, the Servomotor can be used within the intermittent duty zone.
4. If you use a Servomotor Main Circuit Cable that exceeds 20 m, the intermittent duty zone in the torque-motor speed characteristics will become smaller because the voltage drop increases.

## 3.2.4 Servomotor Overload Protection Characteristics

The overload detection level is set for hot start conditions with a Servomotor surrounding air temperature of 40°C.

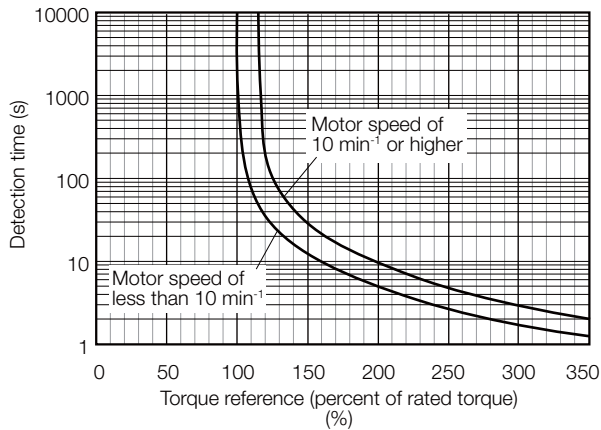

Note: The above overload protection characteristics do not mean that you can perform continuous duty operation with an output of 100% or higher.

Use the Servomotor so that the effective torque remains within the continuous duty zone given in 3.2.3 *Motor Speed-Torque Characteristics* on page 3-5.

## 3.2.5 Load Moment of Inertia

The load moment of inertia indicates the inertia of the load. The larger the load moment of inertia, the worse the response. If the moment of inertia is too large, operation will become unstable.

The allowable size of the load moment of inertia ( $J_L$ ) for the Servomotor is restricted. Refer to 3.2.2 *Servomotor Ratings* on page 3-4.

An Overvoltage Alarm (A.400) is likely to occur during deceleration if the load moment of inertia exceeds the allowable load moment of inertia. SERVOPACKs with a built-in regenerative resistor may generate a Regenerative Overload Alarm (A.320). Perform one of the following steps if this occurs.

- Reduce the torque limit.
- Reduce the deceleration rate.
- Reduce the maximum motor speed.
- Install an external regenerative resistor if the alarm cannot be cleared using the above steps.



## 3.2.6 Servomotor Heat Dissipation Conditions

The Servomotor ratings are the continuous allowable values at a surrounding air temperature of 40°C when a heat sink is installed on the Servomotor. If the Servomotor is mounted on a small device component, the Servomotor temperature may rise considerably because the surface for heat dissipation becomes smaller. Refer to the following graphs for the relation between the heat sink size and derating rate.

Also, change the overload warning and overload alarm detection timing in advance based on the overload detection level of the motor. Refer to the following section for the overload detection level of the motor.

 **3.2.4 Servomotor Overload Protection Characteristics** on page 3-6

Note: The derating rates are applicable only when the average motor speed is less than or equal to the rated motor speed. If the average motor speed exceeds the rated motor speed, consult with your Yaskawa representative.



Important

The actual temperature rise depends on how the heat sink (i.e., the Servomotor mounting section) is attached to the installation surface, what material is used for the Servomotor mounting section, and the motor speed. Always check the Servomotor temperature with the actual equipment.

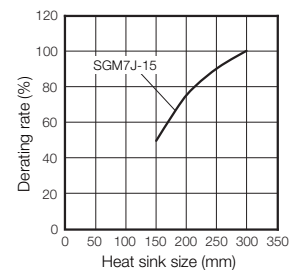
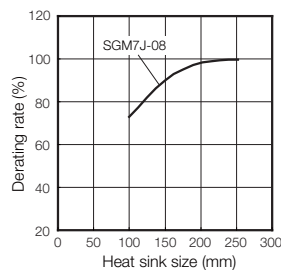
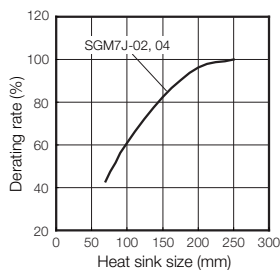

## 3.2.7 Applications Where the Surrounding Air Temperature of the Servomotor Exceeds 40°C

The Servomotor ratings are the continuous allowable values at a surrounding air temperature of 40°C. If you use a Servomotor at a surrounding air temperature that exceeds 40°C (60°C max.), apply a suitable derating rate from the following graphs.

Also, change the overload warning and overload alarm detection timing in advance based on the overload detection level of the motor. Refer to the following section for the overload detection level of the motor.

 **3.2.4 Servomotor Overload Protection Characteristics** on page 3-6

Note: 1. Use the combination of the SERVOPACK and Servomotor so that the derating conditions are satisfied for both the SERVOPACK and Servomotor.

2. The derating rates are applicable only when the average motor speed is less than or equal to the rated motor speed. If the average motor speed exceeds the rated motor speed, consult with your Yaskawa representative.

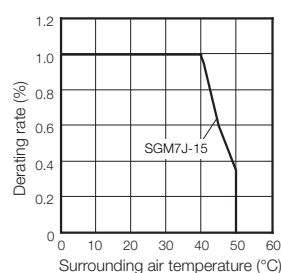
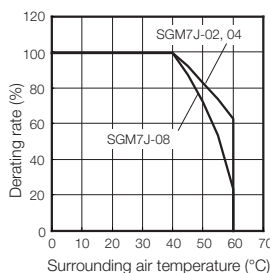

## 3.2.8 Applications Where the Altitude of the Servomotor Exceeds 1,000 m

The Servomotor ratings are the continuous allowable values at an altitude of 1,000 m or less. If you use a Servomotor at an altitude that exceeds 1,000 m (2,000 m max.), the heat dissipation effect of the air is reduced. Apply the appropriate derating rate from the following graphs.

Also, change the overload warning and overload alarm detection timing in advance based on the overload detection level of the motor. Refer to the following section for the overload detection level of the motor.

 **3.2.4 Servomotor Overload Protection Characteristics on page 3-6**

Note: 1. Use the combination of the SERVOPACK and Servomotor so that the derating conditions are satisfied for both the SERVOPACK and Servomotor.

2. The derating rates are applicable only when the average motor speed is less than or equal to the rated motor speed. If the average motor speed exceeds the rated motor speed, consult with your Yaskawa representative.

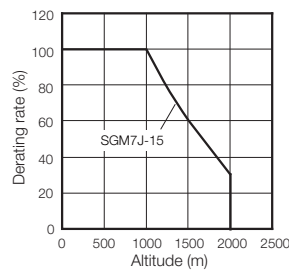
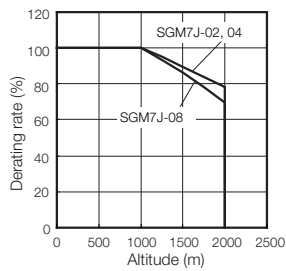

## 3.3 External Dimensions

### 3.3.1 Servomotors

#### SGM7J-02 and -04

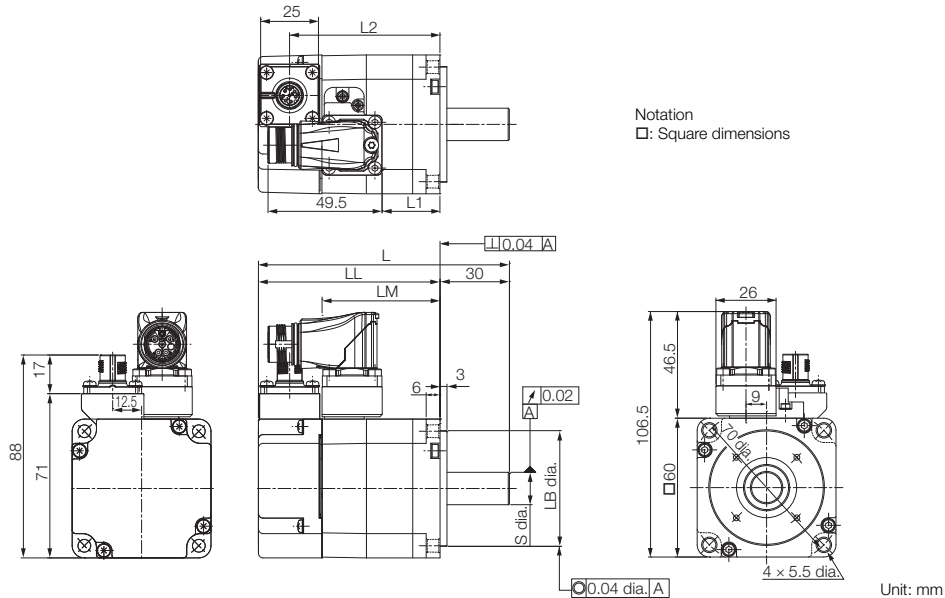

Model SGM7J-	L	LL	LM	LB	S	L1	L2	Approx. Mass [kg]
02D□F2□	108.5 (148.5)	78.5 (118.5)	51.2	50 <sup>0</sup> <sub>-0.025</sub>	14 <sup>0</sup> <sub>-0.011</sub>	25	65 (105)	0.9 (1.5)
04D□F2□	125 (165)	95 (135)	67.2	50 <sup>0</sup> <sub>-0.025</sub>	14 <sup>0</sup> <sub>-0.011</sub>	41.5	81.5 (121.5)	1.2 (1.8)

Note: 1. The values in parentheses are for Servomotors with Holding Brakes.

2. Refer to the following section for detailed shaft end specifications.

☞ 3.3.2 Shaft End Specifications on page 3-12

Refer to the following section for information on connectors.

☞ SGM7J-02 to -08 on page 3-13

### 3.3 External Dimensions

#### 3.3.1 Servomotors

## SGM7J-08

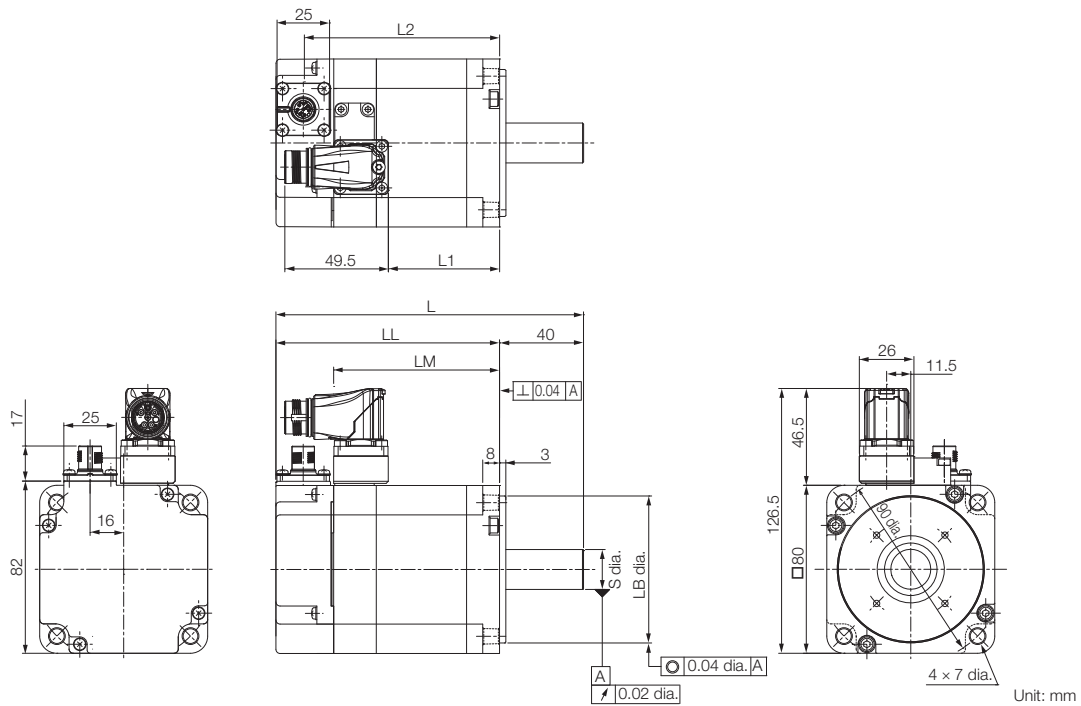

Model SGM7J-	L	LL	LM	LB	S	L1	L2	Approx. Mass [kg]
08D□F2□	146.5 (193.5)	106.5 (153.5)	79	70 <sup>0</sup> <sub>-0.030</sub>	19 <sup>0</sup> <sub>-0.013</sub>	53	93 (140)	2.3 (2.9)

Note: 1. The values in parentheses are for Servomotors with Holding Brakes.

2. Refer to the following section for detailed shaft end specifications.

☞ 3.3.2 Shaft End Specifications on page 3-12

Refer to the following section for information on connectors.

☞ SGM7J-02 to -08 on page 3-13

## SGM7J-15

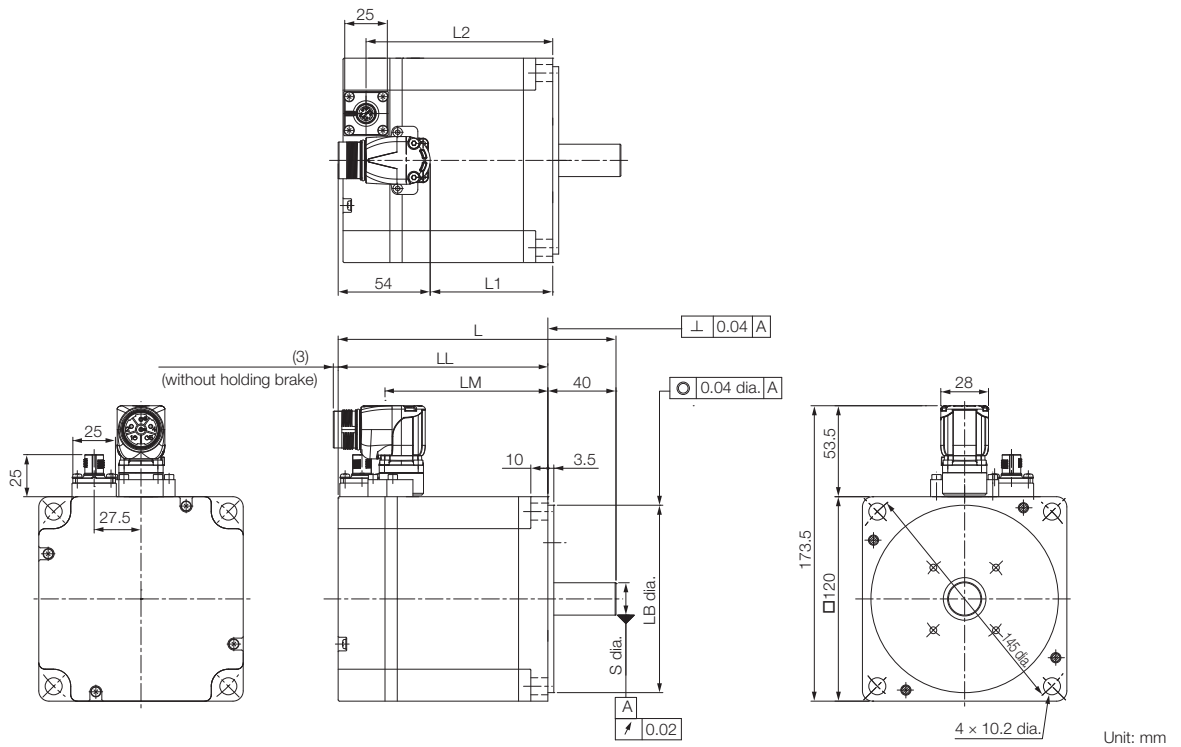

Model SGM7J-	L	LL	LM	LB	S	L1	L2	Approx. Mass [kg]
15D□F2□	163.5 (196.5)	123.5 (156.5)	95.6	110 <sup>0</sup> <sub>-0.035</sub>	19 <sup>0</sup> <sub>-0.013</sub>	72	110 (143)	6.4 (8.1)

Note: 1. The values in parentheses are for Servomotors with Holding Brakes.

2. Refer to the following section for detailed shaft end specifications.

3.3.2 Shaft End Specifications on page 3-12

Refer to the following section for information on connectors.

SGM7J-15 on page 3-13

## 3.3.2 Shaft End Specifications

### SGM7J-□□□□□□□□

Code	Specification
2	Straight without key
6	Straight with key and tap for one location (Key slot is JIS B1301-1996 fastening type.)

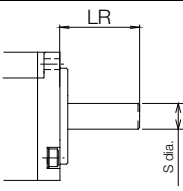
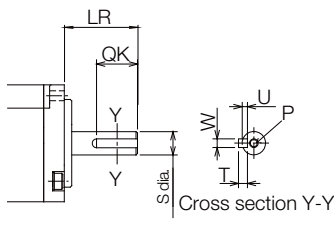
Shaft End Details	Servomotor Model SGM7J-			
	02	04	08	15
Code: 2 (Straight without Key)				
	LR	30	40	
	S	14 <sup>0</sup> <sub>-0.011</sub>	19 <sup>0</sup> <sub>-0.013</sub>	
Code: 6 (Straight with Key and Tap)				
	LR	30	40	
	QK	14	22	
	S	14 <sup>0</sup> <sub>-0.011</sub>	19 <sup>0</sup> <sub>-0.013</sub>	
	W	5	6	
	T	5	6	
	U	3	3.5	
	P	M5 × 8L	M6 × 10L	

### 3.3.3 Connector Specifications

#### SGM7J-02 to -08

• Encoder Connector Specifications

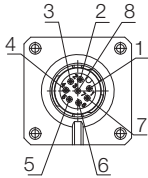

Receptacle  
 Size: M12  
 Part number: 1419959  
 Model: SACC-MSQ-M12MS-25-3,2  
 SCO  
 Manufacturer: Phoenix Contact

1	PG 5V	6	Data (+)
2	PG 0V	7	Data (-)
3	FG	8	Empty
4	BAT (+)	Hous- ing	Shield
5	BAT (-)		

• Servomotor Connector Specifications

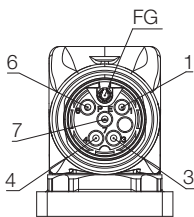

Receptacle  
 Size: M17  
 Part number: 1620448  
 Model: ST-5EP1N8AA500S  
 Manufacturer: Phoenix Contact

1	(Brake)	7	W
3	U	FG	FG
4	V	Hous- ing	Shield
5	Empty		
6	(Brake)		

#### SGM7J-15

• Encoder Connector Specifications

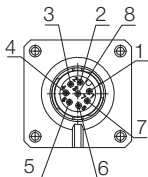

Receptacle  
 Size: M12  
 Part number: 1419959  
 Model: SACC-MSQ-M12MS-25-3,2  
 SCO  
 Manufacturer: Phoenix Contact

1	PG 5V	6	Data (+)
2	PG 0V	7	Data (-)
3	FG	8	Empty
4	BAT (+)	Hous- ing	Shield
5	BAT (-)		

• Servomotor Connector Specifications

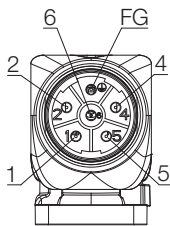

Receptacle  
 Size: M23  
 Part number: 1617905  
 Model: ST-5EP1N8AAD00S  
 Manufacturer: Phoenix Contact

1	V	6	W
2	(Brake)	FG	FG
4	(Brake)	Hous- ing	Shield
5	U		

#### Servomotor Connector Rotational Angle

Allowable number of rotations: 10

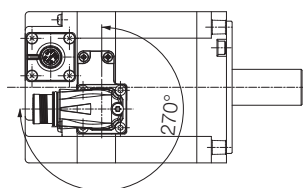

# Specifications, Ratings, and External Dimensions of SGM7A Servomotors

# 4

This chapter describes how to interpret the model numbers of SGM7A Servomotors and gives their specifications, ratings, and external dimensions.

<b>4.1</b>	<b>Model Designations</b> .....	<b>4-2</b>
<b>4.2</b>	<b>Specifications and Ratings</b> .....	<b>4-3</b>
4.2.1	Specifications .....	4-3
4.2.2	Servomotor Ratings .....	4-4
4.2.3	Motor Speed-Torque Characteristics .....	4-6
4.2.4	Servomotor Overload Protection Characteristics	4-7
4.2.5	Load Moment of Inertia .....	4-7
4.2.6	Servomotor Heat Dissipation Conditions .....	4-8
4.2.7	Applications Where the Surrounding Air Temperature of the Servomotor Exceeds 40°C ..	4-9
4.2.8	Applications Where the Altitude of the Servomotor Exceeds 1,000 m .....	4-10
<b>4.3</b>	<b>External Dimensions</b> .....	<b>4-11</b>
4.3.1	Servomotors: SGM7A-02 to -10 .....	4-11
4.3.2	Shaft End Specifications for SGM7A-02 to -10 .....	4-14
4.3.3	Servomotors: SGM7A-15 to -70 .....	4-15
4.3.4	Shaft End Specifications for SGM7A-15 to -70 .....	4-18
4.3.5	Connector Specifications .....	4-19



# 4.1 Model Designations

SGM7A - 02 D 7 F 2 1

Σ-7 Series  
Servomotors:  
SGM7A

1st+2nd  
digits

3rd  
digit

4th  
digit

5th  
digit

6th  
digit

7th  
digit

1st+2nd digits Rated Output

Code	Specification
02	200 W
04	400 W
08	750 W
10	1.0 kW
15	1.5 kW
20	2.0 kW
25	2.5 kW
30	3.0 kW
40	4.0 kW
50	5.0 kW
70	7.0 kW

3rd digit Power Supply Voltage

Code	Specification
D	400 VAC

4th digit Serial Encoder

Code	Specification
7	24-bit absolute
F	24-bit incremental

5th digit Design Revision Order  
F

6th digit Shaft End

Code	Specification
2	Straight without key
6	Straight with key and tap

7th digit Options

Code	Specification
1	Without options
C* <sup>1</sup>	With holding brake (24 VDC)
F* <sup>2</sup>	With dust seal
H* <sup>3</sup>	With dust seal and holding brake (24 VDC)

\*1. This option is not supported for SGM7A-70 Servomotors.  
 \*2. This option is supported only for SGM7A-10 to -70 Servomotors.  
 \*3. This option is supported only for SGM7A-10 to -50 Servomotors.

## 4.2 Specifications and Ratings

### 4.2.1 Specifications

Voltage		400 V											
Model SGM7A-		02D	04D	08D	10D	15D	20D	25D	30D	40D	50D	70D	
Time Rating		Continuous											
Thermal Class		B					F						
Insulation Resistance		500 VDC, 10 MΩ min.											
Withstand Voltage		1,800 VAC for 1 minute											
Excitation		Permanent magnet											
Mounting		Flange-mounted											
Drive Method		Direct drive											
Rotation Direction		Counterclockwise (CCW) for forward reference when viewed from the load side											
Rotation Direction		V15											
Environmental Conditions	Surrounding Air Temperature	0°C to 40°C (With derating, usage is possible between 40°C and 60°C.)* <sup>4</sup>											
	Surrounding Air Humidity	20% to 80% relative humidity (with no condensation)											
	Installation Site	<ul style="list-style-type: none"> <li>• Must be indoors and free of corrosive and explosive gases.</li> <li>• Must be well-ventilated and free of dust and moisture.</li> <li>• Must facilitate inspection and cleaning.</li> <li>• Must have an altitude of 1,000 m or less. (With derating, usage is possible between 1,000 m and 2,000 m.)*<sup>5</sup></li> <li>• Must be free of strong magnetic fields.</li> </ul>											
	Storage Environment	Store the Servomotor in the following environment if you store it with the power cable disconnected. Storage temperature: -20°C to 60°C (with no freezing) Storage humidity: 20% to 80% relative humidity (with no condensation)											
Shock Resistance* <sup>2</sup>	Impact Acceleration Rate at Flange	490 m/s <sup>2</sup>											
	Number of Impacts	2 times											
Vibration Resistance* <sup>3</sup>	Vibration Acceleration Rate at Flange	49 m/s <sup>2</sup> (Models 15D to 50D: 24.5 m/s <sup>2</sup> front to back)										14.7 m/s <sup>2</sup>	
Applicable SERVO-PACKs	SGD7S-	1R9D		3R5D		5R4D		8R4D		120D		170D	260D
	SGD7W-	2R6D* <sup>6</sup>	2R6D* <sup>6</sup> or 5R4D* <sup>6</sup>	2R6D or 5R4D* <sup>6</sup>	5R4D* <sup>6</sup>	5R4D		-					

\*1. A vibration class of V15 indicates a vibration amplitude of 15 μm maximum on the Servomotor without a load at the rated motor speed.

\*2. The shock resistance for shock in the vertical direction when the Servomotor is mounted with the shaft in a horizontal position is given in the above table.

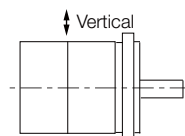

Shock Applied to the Servomotor

\*3. The vertical, side-to-side, and front-to-back vibration resistance for vibration in three directions when the Servomotor is mounted with the shaft in a horizontal position is given in the above table. The strength of the vibration that the Servomotor can withstand depends on the application. Always check the vibration acceleration rate that is applied to the Servomotor with the actual equipment.

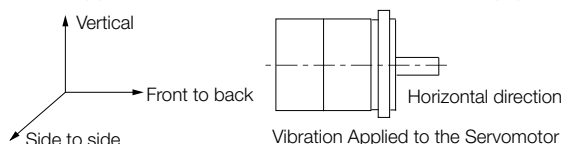

Vibration Applied to the Servomotor

## 4.2 Specifications and Ratings

### 4.2.2 Servomotor Ratings

\*4. Refer to the following section if the surrounding air temperature exceeds 40°C.

 4.2.7 Applications Where the Surrounding Air Temperature of the Servomotor Exceeds 40°C on page 4-9

\*5. If the altitude will exceed 1,000 m, refer to the following section.

 4.2.8 Applications Where the Altitude of the Servomotor Exceeds 1,000 m on page 4-10

\*6. If you use this combination, performance may not be as good, e.g., the control gain may not increase, in comparison with using a Σ-7S SERVOPACK.

## 4.2.2 Servomotor Ratings

Voltage		400 V											
Model SGM7A-		02D	04D	08D	10D	15D	20D	25D	30D	40D	50D	70D	
Rated Output* <sup>1</sup>	W	200	400	750	1000	1500	2000	2500	3000	4000	5000	7000	
Rated Torque* <sup>1, *2</sup>	N·m	0.637	1.27	2.39	3.18	4.90	6.36	7.96	9.80	12.6	15.8	22.3	
Instantaneous Maximum Torque* <sup>1</sup>	N·m	2.23	4.46	8.36	11.1	14.7	19.1	23.9	29.4	37.8	47.6	54.0	
Rated Current* <sup>1</sup>	Arms	1.2	1.2	2.2	3.2	4.7	6.1	7.4	8.9	12.5	13.8	19.2	
Instantaneous Maximum Current* <sup>1</sup>	Arms	5.1	4.9	8.5	12.0	14.0	20.0	25.0	28.0	38	42	52.5	
Rated Motor Speed* <sup>1</sup>	min <sup>-1</sup>	3000											
Maximum Motor Speed* <sup>1</sup>	min <sup>-1</sup>	6000* <sup>7</sup>											
Torque Constant	N·m/ Arms	0.556	1.11	1.16	1.07	1.23	1.18	1.15	1.16	1.06	1.21	1.21	
Motor Moment of Inertia	×10 <sup>-4</sup> kg·m <sup>2</sup>	0.139 (0.209)	0.216 (0.286)	0.775 (0.955)	0.971 (1.15)	2.00 (2.25)	2.47 (2.72)	3.19 (3.44)	7.00 (9.20)	9.60 (11.8)	12.3 (14.5)	12.3	
Rated Power Rate* <sup>1</sup>	kW/s	29.2 (19.4)	74.7 (56.3)	73.7 (59.8)	104 (87.9)	120 (106)	164 (148)	199 (184)	137 (104)	165 (134)	203 (172)	404	
Rated Angular Acceleration Rate* <sup>1</sup>	rad/s <sup>2</sup>	45800 (30400)	58700 (44400)	30800 (25000)	32700 (27600)	24500 (21700)	25700 (23300)	24900 (23100)	14000 (10600)	13100 (10600)	12800 (10800)	18100	
Derating Rate for Servomotor with Dust Seal	%	-			95	100							
Heat Sink Size (aluminum)	mm	250 × 250 × 6			300 × 300 × 12				400 × 400 × 20				
Protective Structure* <sup>3</sup>	Totally enclosed, self-cooled, IP67											Totally enclosed, separately cooled (with fan), IP22	
Holding Brake Specifications* <sup>4</sup>	Rated Voltage	V	24 VDC±10%										-
	Capacity	W	6		6.5		12			10		-	
	Holding Torque	N·m	0.637	1.27	2.39	3.18	7.84	7.84	10.0	20.0			-
	Coil Resistance	Ω (at 20°C)	96±10%		88.6±10%		48±10%			59		-	
	Rated Current	A (at 20°C)	0.25		0.27		0.5			0.41		-	
	Time Required to Release Brake	ms	60		80		170			100		-	
	Time Required to Brake	ms	100				80				-		

Continued on next page.

Continued from previous page.

Voltage			400 V										
Model SGM7A-			02D	04D	08D	10D	15D	20D	25D	30D	40D	50D	70D
Allowable Load Moment of Inertia (Motor Moment of Inertia Ratio) *5	Standard		30 times	20 times			10 times			5 times			15 times *8
	With External Regenerative Resistor or Dynamic Brake Resistor Connected		30 times	20 times	30 times*8			20 times*8			15 times*8		
Allowable Shaft Loads *6	LF	mm	25		35		45			63			
	Allowable Radial Load	N	245		392		686			980	1176		
	Allowable Thrust Load	N	74		147		196			392			

Note: The values in parentheses are for Servomotors with Holding Brakes.

- \*1. For the SGM7A-02D to SGM7A-10D, these values are for operation in combination with a SERVOPACK when the temperature of the armature winding is 100°C. The values for other items are at 20°C. For the SGM7A-15D to SGM7A-70D, these values are for operation in combination with a SERVOPACK when the temperature of the armature winding is 20°C. These are typical values.
- \*2. The rated torques are the continuous allowable torque values at a surrounding air temperature of 40°C with an aluminum heat sink of the dimensions given in the table.
- \*3. This does not apply to the shaft opening. Protective structure specifications apply only when the special cable is used.
- \*4. Observe the following precautions if you use a Servomotor with a Holding Brake.
- The holding brake cannot be used to stop the Servomotor.
  - The time required to release the brake and the time required to brake depend on which discharge circuit is used.  
Confirm that the operation delay time is appropriate for the actual equipment.
  - The 24-VDC power supply is not provided by Yaskawa.
- \*5. The motor moment of inertia scaling factor is the value for a standard Servomotor without a Holding Brake.
- \*6. The allowable shaft loads are illustrated in the following figure. Design the mechanical system so that the thrust and radial loads applied to the Servomotor shaft end during operation do not exceed the values given in the table.

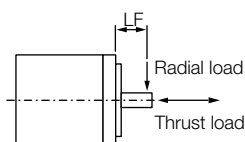

- \*7. For the SGM7A-25D and SGM7A-50D, the maximum motor speed for the continuous duty zone is 5,000 min<sup>-1</sup>. Use the Servomotor within the continuous duty zone for the average motor speed and effective torque.
- \*8. When the Tuning-less function is enabled, the Servomotor may vibrate even if it does not exceed the allowable load moment of inertia.

## 4.2.3 Motor Speed-Torque Characteristics

**A** : Continuous duty zone

**B** : Intermittent duty zone

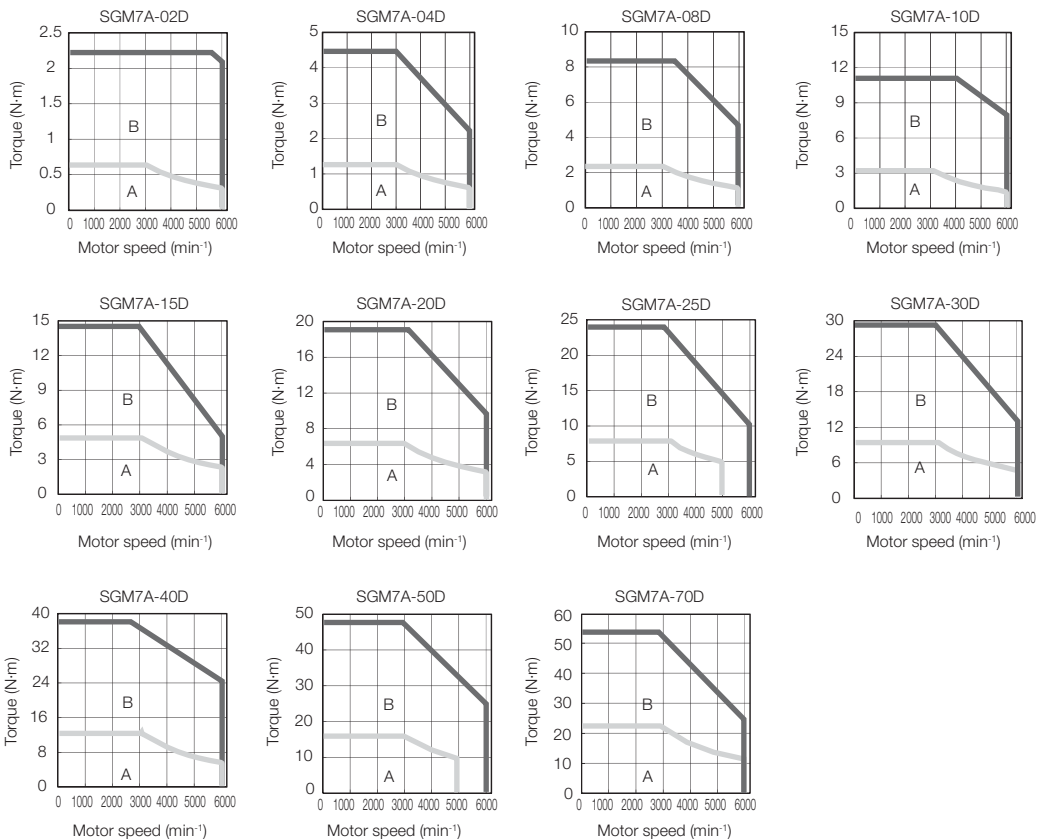

Note: 1. For the SGM7A-02D to SGM7A-10D, these values are for operation in combination with a SERVOPACK when the temperature of the armature winding is 100°C.

For the SGM7A-15D to SGM7A-70D, these values are for operation in combination with a SERVOPACK when the temperature of the armature winding is 20°C. These are typical values.

2. The characteristics in the intermittent duty zone depend on the power supply voltage. The intermittent duty zones in the graphs show the characteristics when a three-phase, 400-VAC power supply voltage is used.
3. If the effective torque is within the allowable range for the rated torque, the Servomotor can be used within the intermittent duty zone.
4. If you use a Servomotor Main Circuit Cable that exceeds 20 m, the intermittent duty zone in the torque-motor speed characteristics will become smaller because the voltage drop increases.

## 4.2.4 Servomotor Overload Protection Characteristics

The overload detection level is set for hot start conditions with a Servomotor surrounding air temperature of 40°C.

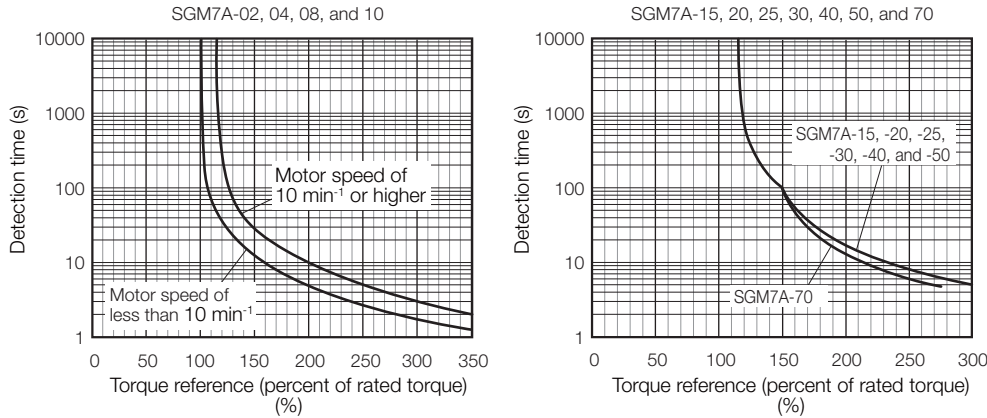

Note: The above overload protection characteristics do not mean that you can perform continuous duty operation with an output of 100% or higher. Use the Servomotor so that the effective torque remains within the continuous duty zone given in 4.2.3 *Motor Speed-Torque Characteristics* on page 4-6.

## 4.2.5 Load Moment of Inertia

The load moment of inertia indicates the inertia of the load. The larger the load moment of inertia, the worse the response. If the moment of inertia is too large, operation will become unstable.

The allowable size of the load moment of inertia ( $J_L$ ) for the Servomotor is restricted. Refer to 4.2.2 *Servomotor Ratings* on page 4-4. This value is provided strictly as a guideline and results depend on Servomotor driving conditions.

An Overvoltage Alarm (A.400) is likely to occur during deceleration if the load moment of inertia exceeds the allowable load moment of inertia. SERVOPACKs with a built-in regenerative resistor may generate a Regenerative Overload Alarm (A.320). Perform one of the following steps if this occurs.

- Reduce the torque limit.
- Reduce the deceleration rate.
- Reduce the maximum motor speed.
- Install an external regenerative resistor if the alarm cannot be cleared using the above steps.

## 4.2.6 Servomotor Heat Dissipation Conditions

The Servomotor ratings are the continuous allowable values at a surrounding air temperature of 40°C when a heat sink is installed on the Servomotor. If the Servomotor is mounted on a small device component, the Servomotor temperature may rise considerably because the surface for heat dissipation becomes smaller. Refer to the following graphs for the relation between the heat sink size and derating rate.

Also, change the overload warning and overload alarm detection timing in advance based on the overload detection level of the motor. Refer to the following section for the overload detection level of the motor.

 **4.2.4 Servomotor Overload Protection Characteristics on page 4-7**

Note: The derating rates are applicable only when the average motor speed is less than or equal to the rated motor speed. If the average motor speed exceeds the rated motor speed, consult with your Yaskawa representative.



**Important** The actual temperature rise depends on how the heat sink (i.e., the Servomotor mounting section) is attached to the installation surface, what material is used for the Servomotor mounting section, and the motor speed. Always check the Servomotor temperature with the actual equipment.

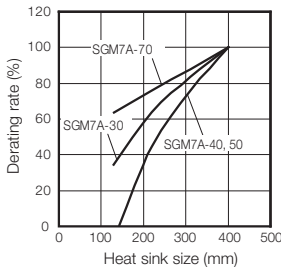
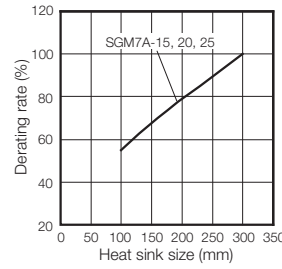
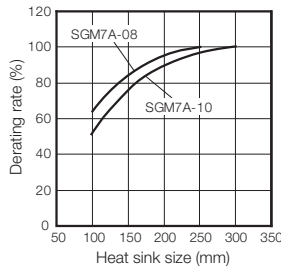
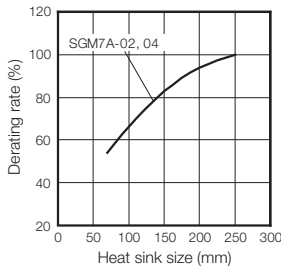

## 4.2.7 Applications Where the Surrounding Air Temperature of the Servomotor Exceeds 40°C

The Servomotor ratings are the continuous allowable values at a surrounding air temperature of 40°C. If you use a Servomotor at a surrounding air temperature that exceeds 40°C (60°C max.), apply a suitable derating rate from the following graphs.

Also, change the overload warning and overload alarm detection timing in advance based on the overload detection level of the motor. Refer to the following section for the overload detection level of the motor.

### 4.2.4 Servomotor Overload Protection Characteristics on page 4-7

Note: 1. Use the combination of the SERVOPACK and Servomotor so that the derating conditions are satisfied for both the SERVOPACK and Servomotor.

2. The derating rates are applicable only when the average motor speed is less than or equal to the rated motor speed. If the average motor speed exceeds the rated motor speed, consult with your Yaskawa representative.

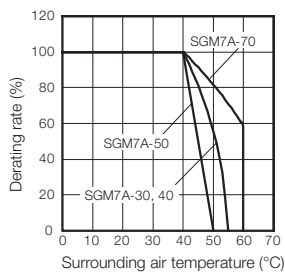
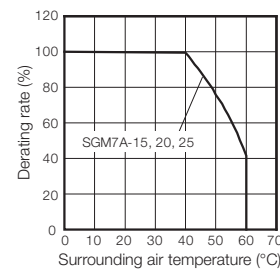
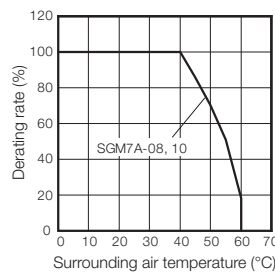
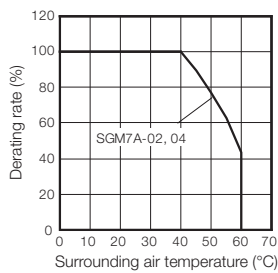



## 4.2.8 Applications Where the Altitude of the Servomotor Exceeds 1,000 m

The Servomotor ratings are the continuous allowable values at an altitude of 1,000 m or less. If you use a Servomotor at an altitude that exceeds 1,000 m (2,000 m max.), the heat dissipation effect of the air is reduced. Apply the appropriate derating rate from the following graphs.

Also, change the overload warning and overload alarm detection timing in advance based on the overload detection level of the motor. Refer to the following section for the overload detection level of the motor.

 **4.2.4 Servomotor Overload Protection Characteristics on page 4-7**

Note: 1. Use the combination of the SERVOPACK and Servomotor so that the derating conditions are satisfied for both the SERVOPACK and Servomotor.

2. The derating rates are applicable only when the average motor speed is less than or equal to the rated motor speed. If the average motor speed exceeds the rated motor speed, consult with your Yaskawa representative.

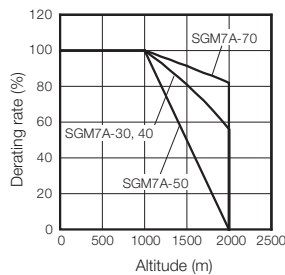
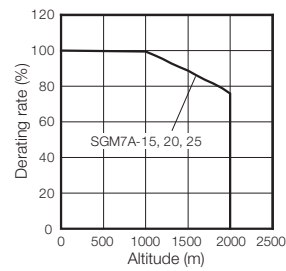
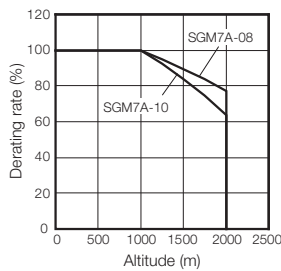
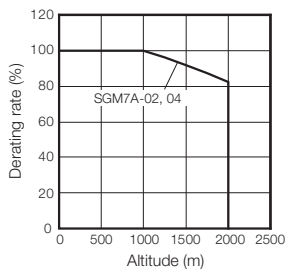

# 4.3 External Dimensions

## 4.3.1 Servomotors: SGM7A-02 to -10

### SGM7A-02 and -04

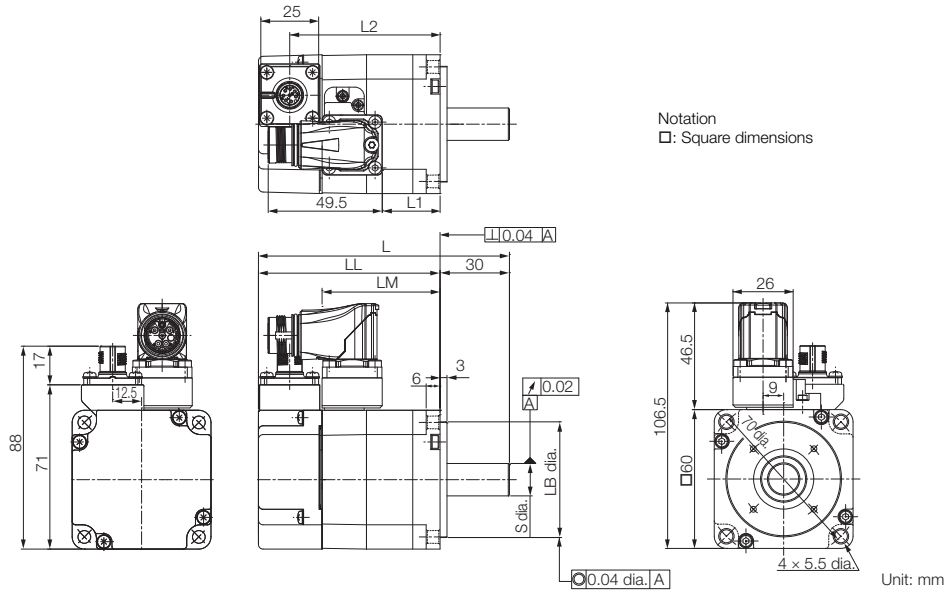

Model SGM7A-	L	LL	LM	LB	S	L1	L2	Approx. Mass [kg]
02D□F2□	108.5 (148.5)	78.5 (118.5)	51.2	50 <sup>0</sup> <sub>-0.025</sub>	14 <sup>0</sup> <sub>-0.011</sub>	25	65 (105)	0.9 (1.5)
04D□F2□	125 (165)	95 (135)	67.2	50 <sup>0</sup> <sub>-0.025</sub>	14 <sup>0</sup> <sub>-0.011</sub>	41.5	81.5 (121.5)	1.3 (1.9)

Note: 1. The values in parentheses are for Servomotors with Holding Brakes.  
 2. Refer to the following section for detailed shaft end specifications.

4.3.2 Shaft End Specifications for SGM7A-02 to -10 on page 4-14

Refer to the following section for information on connectors.

SGM7A-04 and -08 on page 4-19

### 4.3 External Dimensions

#### 4.3.1 Servomotors: SGM7A-02 to -10

## SGM7A-08

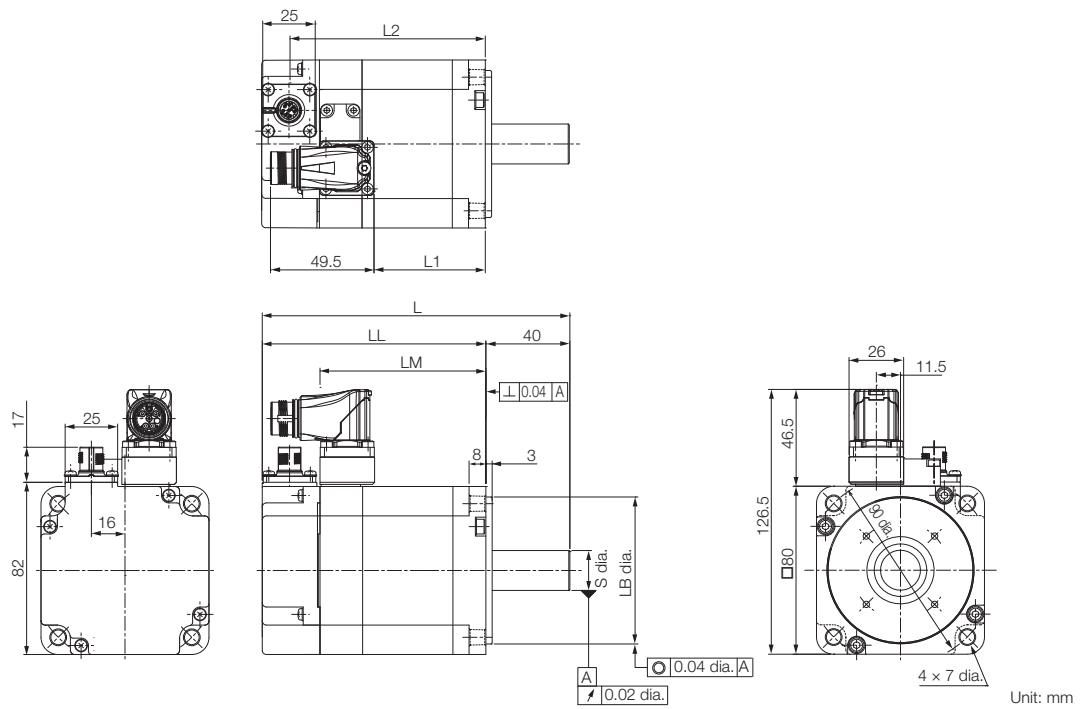

Model SGM7A-	L	LL	LM	LB	S	L1	L2	Approx. Mass [kg]
08D□F2□	146.5 (193.5)	106.5 (153.5)	79	70 <sup>0</sup> <sub>-0.030</sub>	19 <sup>0</sup> <sub>-0.013</sub>	53	93 (140)	2.4 (3.0)

Note: 1. The values in parentheses are for Servomotors with Holding Brakes.

2. Refer to the following section for detailed shaft end specifications.

☞ 4.3.2 Shaft End Specifications for SGM7A-02 to -10 on page 4-14

Refer to the following section for information on connectors.

☞ SGM7A-04 and -08 on page 4-19

# SGM7A-10

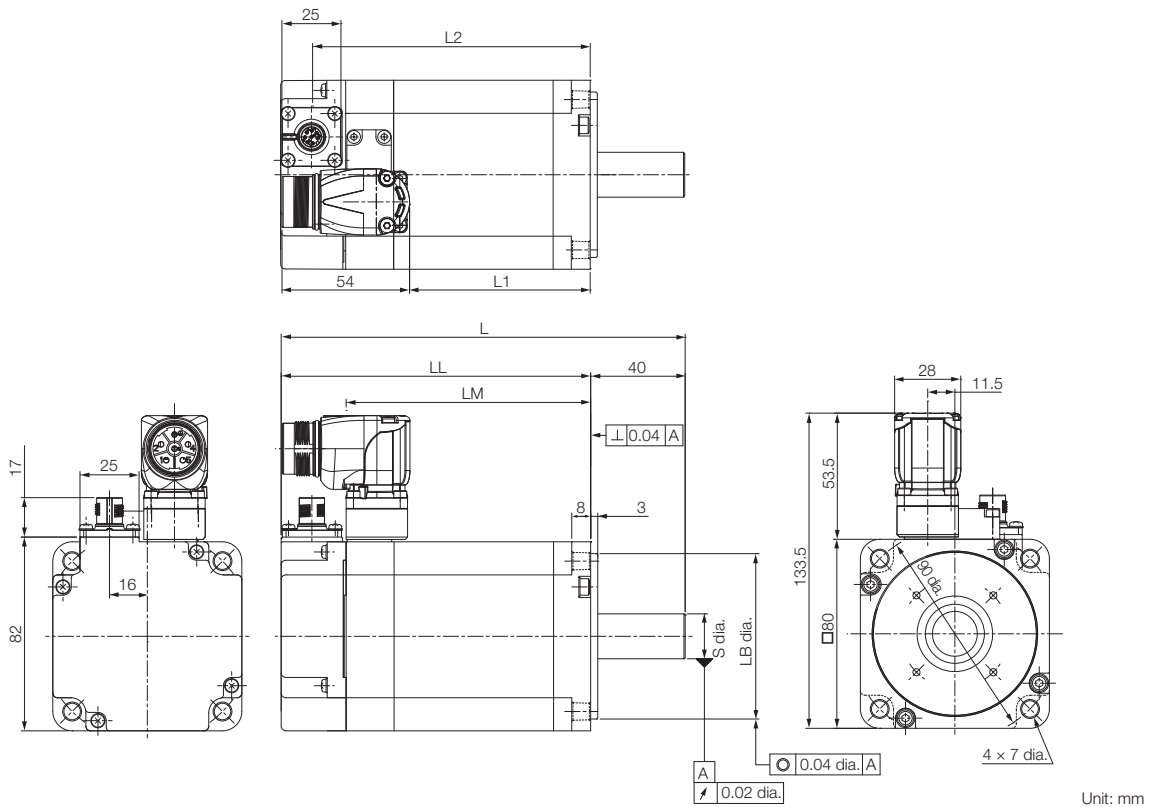

Model SGM7A-	L	LL	LM	LB	S	L1	L2	Approx. Mass [kg]
10D□F2□	171 (218)	131 (178)	103.5	70 <sup>0</sup> <sub>-0.030</sub>	19 <sup>0</sup> <sub>-0.013</sub>	77	117.5 (164.5)	3.2 (3.8)

Note: 1. The values in parentheses are for Servomotors with Holding Brakes.

2. Refer to the following section for detailed shaft end specifications.

☞ 4.3.2 Shaft End Specifications for SGM7A-02 to -10 on page 4-14

Refer to the following section for information on connectors.

☞ SGM7A-10 to -50 on page 4-19

## ◆ Options

- With Dust Seal

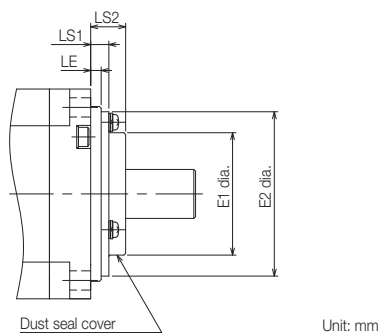

Model SGM7A-	Dimensions with Dust Seal			
	E1	E2	LS1	LS2
10D	47	61	5.5	11

## 4.3.2 Shaft End Specifications for SGM7A-02 to -10

### SGM7A-□□□□□□□□

Code	Specification
2	Straight without key
6	Straight with key and tap for one location (Key slot is JIS B1301-1996 fastening type.)

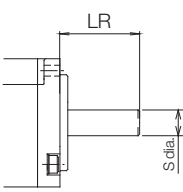
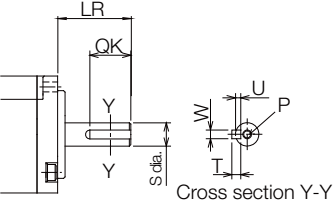
Shaft End Details	Servomotor Model SGM7A-			
	02	04	08	10
Code: 2 (Straight without Key)				
	LR	30	40	
	S	14 <sup>0</sup> <sub>-0.011</sub>	19 <sup>0</sup> <sub>-0.013</sub>	
Code: 6 (Straight with Key and Tap)				
	LR	30	40	
	QK	14	22	
	S	14 <sup>0</sup> <sub>-0.011</sub>	19 <sup>0</sup> <sub>-0.013</sub>	
	W	5	6	
	T	5	6	
	U	3	3.5	
	P	M5 × 8L	M6 × 10L	

### 4.3.3 Servomotors: SGM7A-15 to -70

#### SGM7A-15, -20, and -25

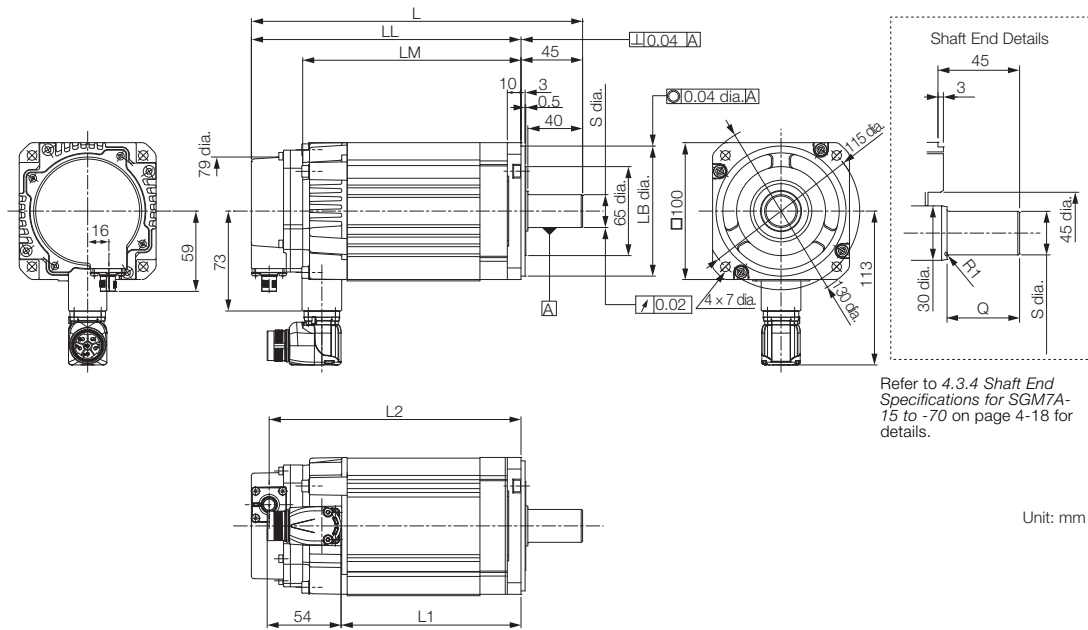

Model SGM7A-	L	LL	LM	L1	L2	LB	Shaft End Dimensions		Approx. Mass [kg]
							S	Q	
15D□F2□	204 (245)	159 (200)	121 (162)	90	145 (187)	95 <sup>0</sup> <sub>-0.035</sub>	24 <sup>0</sup> <sub>-0.013</sub>	40	4.7 (6.1)
20D□F2□	220 (261)	175 (216)	137 (178)	106	161 (203)	95 <sup>0</sup> <sub>-0.035</sub>	24 <sup>0</sup> <sub>-0.013</sub>	40	5.5 (6.9)
25D□F2□	243 (294)	198 (249)	160 (211)	129	184 (235)	95 <sup>0</sup> <sub>-0.035</sub>	24 <sup>0</sup> <sub>-0.013</sub>	40	6.9 (8.8)

Note: 1. The values in parentheses are for Servomotors with Holding Brakes.  
 2. Servomotors with Dust Seals have the same dimensions.

Refer to the following section for information on connectors.

☞ SGM7A-10 to -50 on page 4-19

4.3 External Dimensions

4.3.3 Servomotors: SGM7A-15 to -70

### SGM7A-30 to -50

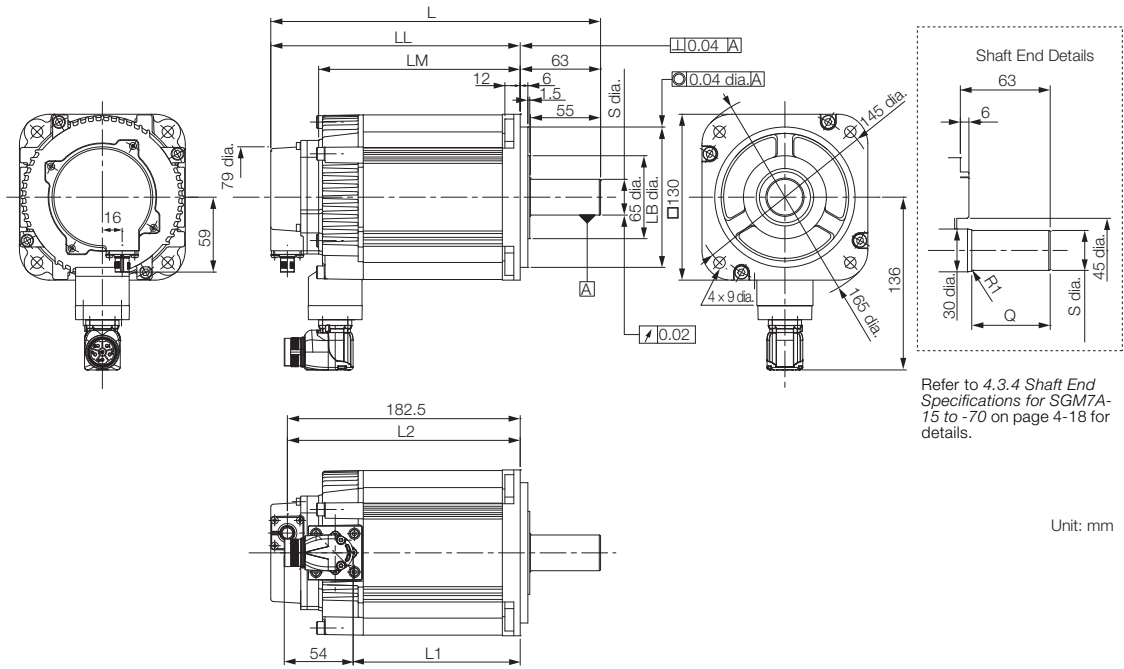

Refer to 4.3.4 Shaft End Specifications for SGM7A-15 to -70 on page 4-18 for details.

Unit: mm

Model SGM7A-	L	LL	LM	L1	L2	LB	Shaft End Dimensions		Approx. Mass [kg]
							S	Q	
30D□F2□	259 (295)	196 (232)	158 (194)	131	183 (219)	110 <sup>0</sup> <sub>-0.035</sub>	28 <sup>0</sup> <sub>-0.013</sub>	55	10.6 (13.1)
40D□F2□	298 (334)	235 (271)	197 (233)	170	222 (258)	110 <sup>0</sup> <sub>-0.035</sub>	28 <sup>0</sup> <sub>-0.013</sub>	55	14.0 (16.5)
50D□F2□	338 (374)	275 (311)	237 (273)	210	262 (298)	110 <sup>0</sup> <sub>-0.035</sub>	28 <sup>0</sup> <sub>-0.013</sub>	55	17.0 (19.5)

Note: 1. The values in parentheses are for Servomotors with Holding Brakes.  
 2. Servomotors with Dust Seals have the same dimensions.

Refer to the following section for information on connectors.

☞ SGM7A-10 to -50 on page 4-19

## SGM7A-70

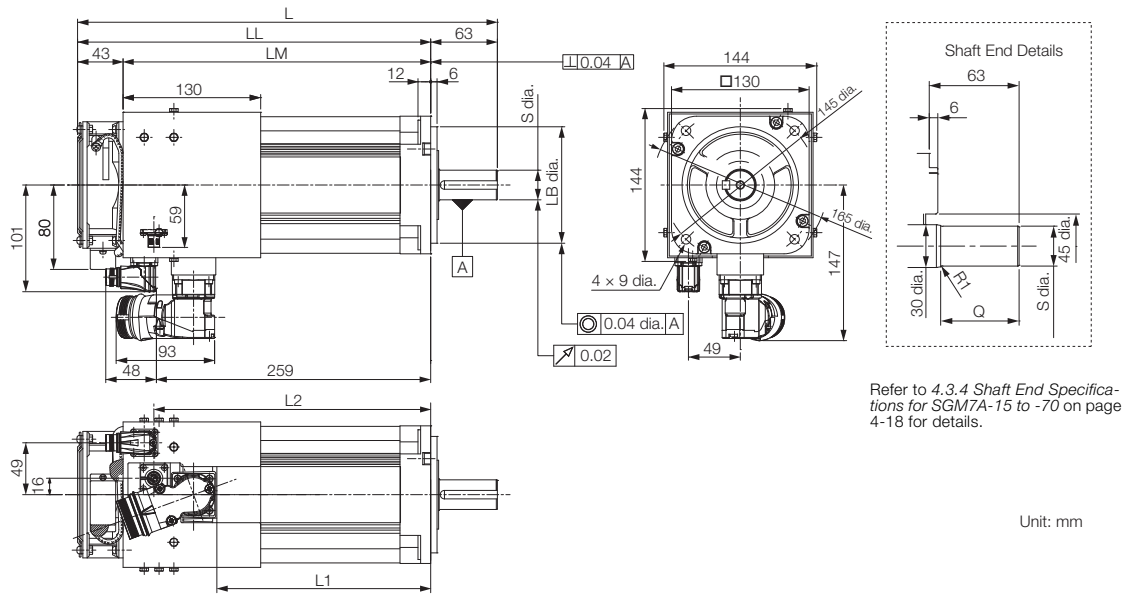

\* Leave a minimum space of 70 mm around the Servomotor from walls and other equipment to allow for a sufficient amount of cooling air.

Model SGM7A-	L	LL	LM	L1	L2	LB	Shaft End Dimensions		Approx. Mass [kg]
							S	Q	
70D□F2□	397	334	291	204	262	110 <sup>0</sup> <sub>-0.035</sub>	28 <sup>0</sup> <sub>-0.013</sub>	55	19.0

Note: Servomotors with Dust Seals have the same dimensions.

Refer to the following section for information on connectors.

☞ SGM7A-70 on page 4-20

### ◆ Cooling Fan Specifications

Single-phase, 220 V

50/60 Hz

17/15 W

0.11/0.09 A

### ◆ Specifications of Fan Operation Error Detector

Contact Capacity

- Maximum allowable voltage: 350 V (AC/DC)
- Maximum allowable current: 120 mA (AC/ DC)
- Maximum controllable power: 360 mW

Alarm Contacts

- ON for normal fan rotation
- OFF at 1,680 ± 100 min<sup>-1</sup> max.
- OFF for 3 seconds at startup.



## 4.3.4 Shaft End Specifications for SGM7A-15 to -70

### SGM7A-□□□□□□□□

Code	Specification
2	Straight without key
6	Straight with key and tap for one location (Key slot is JIS B1301-1996 fastening type.)

Shaft End Details	Servomotor Model SGM7A-						
	15	20	25	30	40	50	70

Code: 2 (Straight without Key)

	LR	45	63
	Q	40	55
	S	24 <sup>0</sup> <sub>-0.013</sub>	28 <sup>0</sup> <sub>-0.013</sub>

Code: 6 (Straight with Key and Tap)

	LR	45	63
	Q	40	55
	QK	32	50
	S	24 <sup>0</sup> <sub>-0.013</sub>	28 <sup>0</sup> <sub>-0.013</sub>
	W	8	
	T	7	
	U	4	
P	M8 screw, Depth: 16		

## 4.3.5 Connector Specifications

### SGM7A-04 and -08

#### • Encoder Connector Specifications

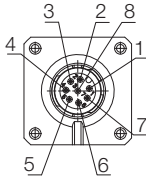

Receptacle  
Size: M12  
Part number: 1419959  
Model: SACC-MSQ-M12MS-25-3,2  
SCO  
Manufacturer: Phoenix Contact

1	PG 5V	6	Data (+)
2	PG 0V	7	Data (-)
3	FG	8	Empty
4	BAT (+)	Housing	Shield
5	BAT (-)		

#### • Servomotor Connector Specifications

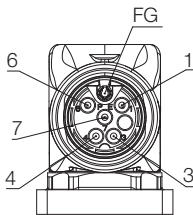

Receptacle  
Size: M17  
Part number: 1620448  
Model: ST-5EP1N8AA500S  
Manufacturer: Phoenix Contact

1	(Brake)	7	W
3	U	FG	FG
4	V	Housing	Shield
5	Empty		
6	(Brake)		

### SGM7A-10 to -50

#### • Encoder Connector Specifications

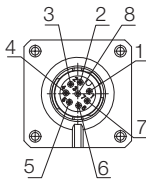

Receptacle  
Size: M12  
Part number: 1419959  
Model: SACC-MSQ-M12MS-25-3,2  
SCO  
Manufacturer: Phoenix Contact

1	PG 5V	6	Data (+)
2	PG 0V	7	Data (-)
3	FG	8	Empty
4	BAT (+)	Housing	Shield
5	BAT (-)		

#### • Servomotor Connector Specifications

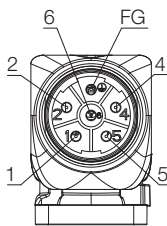

Receptacle  
Size: M23  
Part number: 1617905  
Model: ST-5EP1N8AAD00S  
Manufacturer: Phoenix Contact

1	V	6	W
2	(Brake)	FG	FG
4	(Brake)	Housing	Shield
5	U		

### SGM7A-70

• Encoder Connector Specifications

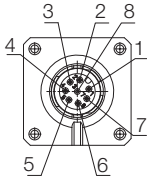

Receptacle  
 Size: M12  
 Part number: 1419959  
 Model: SACC-MSQ-M12MS-25-3,2 SCO  
 Manufacturer: Phoenix Contact

1	PG 5V	6	Data (+)
2	PG 0V	7	Data (-)
3	FG	8	Empty
4	BAT (+)	Housing	Shield
5	BAT (-)		

• Servomotor Connector Specifications

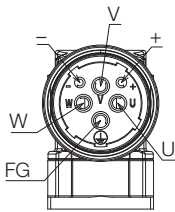

Receptacle  
 Size: M40  
 Part number: 1607927  
 Model: SM-5EPWN8AAD00S  
 Manufacturer: Phoenix Contact

U	U	-	Empty
V	V	FG	FG
W	W	Housing	Shield
+	Empty		

• Fan Connector Specifications

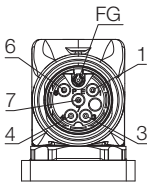

Receptacle  
 Size: M17  
 Part number: 1620448  
 Model: ST-5EP1N8AA500S  
 Manufacturer: Phoenix Contact

1	ALARM TERMINAL
3	FAN MOTOR
4	FAN MOTOR
6	ALARM TERMINAL
7	Empty
FG	FG
Housing	Shield

### Servomotor Connector Rotational Angle

Allowable number of rotations: 10

SGM7A-02 to -10

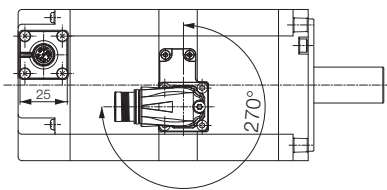

SGM7A-15 to -25

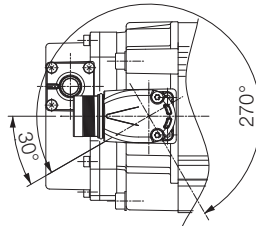

SGM7A-30 to -50

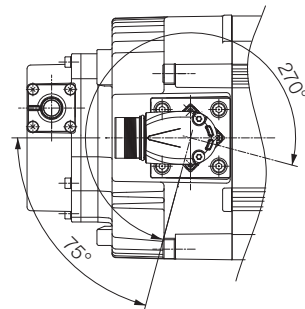

SGM7A-70

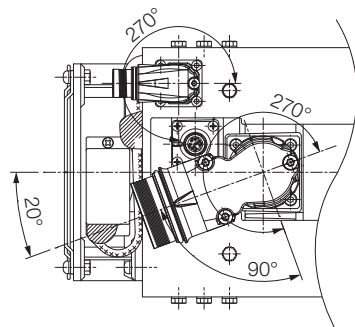

# Specifications, Ratings, and External Dimensions of SGM7G Servomotors

# 5

This chapter describes how to interpret the model numbers of SGM7G Servomotors and gives their specifications, ratings, and external dimensions.

<b>5.1</b>	<b>Model Designations</b> .....	<b>5-2</b>
<b>5.2</b>	<b>Specifications and Ratings</b> .....	<b>5-3</b>
5.2.1	Specifications .....	5-3
5.2.2	Servomotor Ratings .....	5-5
5.2.3	Motor Speed-Torque Characteristics .....	5-9
5.2.4	Servomotor Overload Protection Characteristics .....	5-11
5.2.5	Load Moment of Inertia .....	5-12
5.2.6	Servomotor Heat Dissipation Conditions .....	5-13
5.2.7	Servomotor Derating Rates for Surrounding Air Temperatures .....	5-13
5.2.8	Applications Where the Altitude of the Servomotor Exceeds 1,000 m .....	5-14
<b>5.3</b>	<b>External Dimensions</b> .....	<b>5-15</b>
5.3.1	Servomotors .....	5-15
5.3.2	Shaft End Specifications .....	5-19
5.3.3	Connector Specifications .....	5-20

# 5.1 Model Designations

SGM7G - 05 D 7 F 2 1

1st+2nd digits
3rd digit
4th digit
5th digit
6th digit
7th digit

Σ-7 Series  
Servomotors:  
SGM7G

**1st+2nd digits** Rated Output

Code	Specification
05	450 W
09	850 W
13	1.3 kW
20	1.8 kW
30	2.9 kW
44	4.4 kW
55*1	5.5 kW
75*1	7.5 kW
1A*1	11 kW
1E*1	15 kW

**3rd digit** Power Supply Voltage

Code	Specification
D	400 VAC

**4th digit** Serial Encoder

Code	Specification
7	24-bit absolute
F	24-bit incremental

**5th digit** Design Revision Order

Code	Specification
F	Standard model
R	High-speed model

**6th digit** Shaft End

Code*2	Specification
2 or S	Straight without key
6 or K	Straight with key and tap

**7th digit** Options

Code	Specification
1	Without options
C	With holding brake (24 VDC)
F	With dust seal
H	With dust seal and holding brake (24 VDC)

\*1. The high-speed model specification is not supported for these codes.

\*2. The code for the shaft end depends on the model.  
SGM7G-05, -20, -30, -44, -55, -75, -1A, or -1E: 2 or 6  
SGM7G-09 or -13: S or K

## 5.2 Specifications and Ratings

### 5.2.1 Specifications

Voltage		400 V										
Model SGM7G-		05D	09D	13D	20D	30D	44D	55D	75D	1AD	1ED	
Time Rating		Continuous										
Thermal Class		F										
Insulation Resistance		500 VDC, 10 MΩ min.										
Withstand Voltage		1,800 VAC for 1 minute										
Excitation		Permanent magnet										
Mounting		Flange-mounted										
Drive Method		Direct drive										
Rotation Direction		Counterclockwise (CCW) for forward reference when viewed from the load side										
Vibration Class* <sup>1</sup>		V15										
Environmental Conditions	Surrounding Air Temperature	0°C to 40°C (With derating, usage is possible between 40°C and 60°C.)* <sup>4</sup>										
	Surrounding Air Humidity	20% to 80% relative humidity (with no condensation)										
	Installation Site	<ul style="list-style-type: none"> <li>• Must be indoors and free of corrosive and explosive gases.</li> <li>• Must be well-ventilated and free of dust and moisture.</li> <li>• Must facilitate inspection and cleaning.</li> <li>• Must have an altitude of 1,000 m or less. (With derating, usage is possible between 1,000 m and 2,000 m.)*<sup>5</sup></li> <li>• Must be free of strong magnetic fields.</li> </ul>										
	Storage Environment	Store the Servomotor in the following environment if you store it with the power cable disconnected. Storage temperature: -20°C to 60°C (with no freezing) Storage humidity: 20% to 80% relative humidity (with no condensation)										
Shock Resistance* <sup>2</sup>	Impact Acceleration Rate at Flange	490 m/s <sup>2</sup>										
	Number of Impacts	2 times										
Vibration Resistance* <sup>3</sup>	Vibration Acceleration Rate at Flange	49 m/s <sup>2</sup> (24.5 m/s <sup>2</sup> front to back)							24.5 m/s <sup>2</sup>			
Applicable SERVO-PACKs	When Using a Standard Servomotor	SGD7S-	1R9D	3R5D	5R4D	8R4D	120D	170D	210D	260D	280D	370D
		SGD7W-	2R6D* <sup>6</sup> , or 5R4D* <sup>6</sup>	5R4D* <sup>6</sup>	5R4D	-						
	When Using a High-speed Servomotor	SGD7S-	3R5D	5R4D	8R4D	120D	170D	210D	-			
		SGD7W-	2R6D, or 5R4D* <sup>6</sup>	5R4D	-							

\*1. A vibration class of V15 indicates a vibration amplitude of 15 μm maximum on the Servomotor without a load at the rated motor speed.

\*2. The shock resistance for shock in the vertical direction when the Servomotor is mounted with the shaft in a horizontal position is given in the above table.

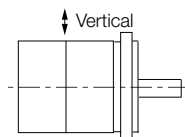

Shock Applied to the Servomotor

## 5.2 Specifications and Ratings

---

### 5.2.1 Specifications

- \*3. The vertical, side-to-side, and front-to-back vibration resistance for vibration in three directions when the Servomotor is mounted with the shaft in a horizontal position is given in the above table. The strength of the vibration that the Servomotor can withstand depends on the application. Always check the vibration acceleration rate that is applied to the Servomotor with the actual equipment.

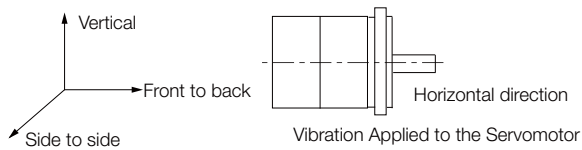

- \*4. Refer to the following section for information on Servomotor derating rates for surrounding air temperatures.  
🔗 **5.2.7 Servomotor Derating Rates for Surrounding Air Temperatures** on page 5-13
- \*5. If the altitude will exceed 1,000 m, refer to the following section.  
🔗 **5.2.8 Applications Where the Altitude of the Servomotor Exceeds 1,000 m** on page 5-14
- \*6. If you use this combination, performance may not be as good, e.g., the control gain may not increase, in comparison with using a  $\Sigma$ -7S SERVOPACK.

## 5.2.2 Servomotor Ratings

### Standard Servomotors

Voltage		400 V										
Model SGM7G-		05D	09D	13D	20D	30D	44D	55D	75D	1AD	1ED	
Rated Output* <sup>1</sup>	kW	0.45	0.85	1.3	1.8	2.9	4.4	5.5	7.5	11	15	
Rated Torque* <sup>1, *2</sup>	N·m	2.86	5.39	8.34	11.5	18.6	28.4	35.0	48.0	70.0	95.4	
Instantaneous Maximum Torque* <sup>1</sup>	N·m	8.92	13.8	23.3	28.7	45.1	71.1	87.6	119	175	224	
Rated Current* <sup>1</sup>	Arms	1.9	3.5	5.4	8.4	11.9	16.0	20.8	25.7	28.1	37.2	
Instantaneous Maximum Current* <sup>1</sup>	Arms	5.5	8.5	14	20	28	40.5	52	65	70	85	
Rated Motor Speed* <sup>1</sup>	min <sup>-1</sup>	1500										
Maximum Motor Speed* <sup>1</sup>	min <sup>-1</sup>	3000								2000		
Torque Constant	N·m/ Arms	1.71	1.72	1.78	1.50	1.70	1.93	1.80	1.92	2.76	2.86	
Motor Moment of Inertia	×10 <sup>-4</sup> kg·m <sup>2</sup>	3.33 (3.58)	13.9 (16.0)	19.9 (22.0)	26.0 (28.1)	46.0 (53.9)	67.5 (75.4)	89 (96.9)	125 (133)	242 (261)	303 (341)	
Rated Power Rate* <sup>1</sup>	kW/s	24.6 (22.8)	20.9 (18.2)	35.0 (31.6)	50.9 (47.1)	75.2 (64.2)	119 (107)	138 (126)	184 (173)	202 (188)	300 (267)	
Rated Angular Acceleration Rate* <sup>1</sup>	rad/s <sup>2</sup>	8590 (7990)	3880 (3370)	4190 (3790)	4420 (4090)	4040 (3450)	4210 (3770)	3930 (3610)	3840 (3610)	2890 (2680)	3150 (2800)	
Heat Sink Size	mm	250 x 250 x 6 (aluminum)	400 x 400 x 20 (steel)			550 x 550 x 30 (steel)			650 x 650 x 35 (steel)			
Protective Structure* <sup>3</sup>		Totally enclosed, self-cooled, IP67										
Holding Brake Specifica- tions* <sup>4</sup>	Rated Voltage	V	24 VDC <sup>+10%<sub>0</sub></sup>									
	Capacity	W	10			18.5		25		32	35	
	Holding Torque	N·m	4.5	12.7	19.6		43.1		72.6		84.3	114.6
	Coil Resistance	Ω (at 20°C)	56	59			31		23		18	17
	Rated Current	A (at 20°C)	0.43	0.41			0.77		1.05		1.33	1.46
	Time Required to Release Brake	ms	100				170		170			250
	Time Required to Brake	ms	80				100		80			

Continued on next page.



5.2 Specifications and Ratings

5.2.2 Servomotor Ratings

Continued from previous page.

Voltage		400 V									
Model SGM7G-		05D	09D	13D	20D	30D	44D	55D	75D	1AD	1ED
Allowable Load Moment of Inertia (Motor Moment of Inertia Ratio) <sup>*5</sup>	Standard	15 times	5 times					10 times <sup>*7</sup>			
	With External Regenerative Resistor or Dynamic Brake Resistor Connected	15 times	10 times <sup>*7</sup>								
Allowable Shaft Loads <sup>*6</sup>	LF	mm	40	58		79		113	116		
	Allowable Radial Load	N	490	686	980	1470	1764		4998		
	Allowable Thrust Load	N	98	343	392	490	588		2156		

Note: The values in parentheses are for Servomotors with Holding Brakes.

- \*1. These values are for operation in combination with a SERVOPACK when the temperature of the armature winding is 20°C. These are typical values.
- \*2. The rated torques are the continuous allowable torque values with an aluminum or steel heat sink of the dimensions given in the table.
- \*3. This does not apply to the shaft opening. Protective structure specifications apply only when the special cable is used.
- \*4. Observe the following precautions if you use a Servomotor with a Holding Brake.
  - The holding brake cannot be used to stop the Servomotor.
  - The time required to release the brake and the time required to brake depend on which discharge circuit is used. Confirm that the operation delay time is appropriate for the actual equipment.
  - The 24-VDC power supply is not provided by Yaskawa.
- \*5. The motor moment of inertia scaling factor is the value for a standard Servomotor without a Holding Brake.
- \*6. The allowable shaft loads are illustrated in the following figure. Design the mechanical system so that the thrust and radial loads applied to the Servomotor shaft end during operation do not exceed the values given in the table.

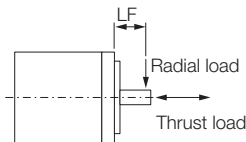

- \*7. When the Tuning-less function is enabled, the Servomotor may vibrate even if it does not exceed the allowable load moment of inertia.

## High-speed Servomotors

Voltage		400 V					
Model SGM7G-		05D	09D	13D	20D	30D	44D
Rated Output* <sup>1</sup>	kW	0.45	0.85	1.3	1.8	2.9	4.4
Rated Torque* <sup>1, *2</sup>	N·m	2.86	5.39	8.34	11.5	18.6	28.4
Instantaneous Maximum Torque* <sup>1</sup>	N·m	8.80	15.0	22.0	28.7	50.0	71.1
Rated Current* <sup>1</sup>	Arms	2.6	5.3	8.3	10.1	14.4	19.3
Instantaneous Maximum Current* <sup>1</sup>	Arms	8.2	14.0	21	24	40	50
Rated Motor Speed* <sup>1</sup>	min <sup>-1</sup>	1500					
Maximum Motor Speed* <sup>1</sup>	min <sup>-1</sup>	5000				4500	
Allowable Continuous Motor Speed	min <sup>-1</sup>	5000	4000			3300	3000
Torque Constant	N·m/Arms	1.13	1.12	1.09	1.27	1.36	1.58
Motor Moment of Inertia	$\times 10^{-4}$ kg·m <sup>2</sup>	3.33 (3.58)	13.9 (16.0)	19.9 (22.0)	26.0 (28.1)	46.0 (53.9)	67.5 (75.4)
Rated Power Rate* <sup>1</sup>	kW/s	24.6 (22.8)	20.9 (18.2)	35.0 (31.6)	50.9 (47.1)	75.2 (64.2)	119 (107)
Rated Angular Acceleration Rate* <sup>1</sup>	rad/s <sup>2</sup>	8590 (7990)	3880 (3370)	4190 (3790)	4420 (4090)	4040 (3450)	4210 (3770)
Heat Sink Size	mm	250 × 250 × 6 (aluminum)	400 × 400 × 20 (steel)				
Protective Structure* <sup>3</sup>		Totally enclosed, self-cooled, IP67					
Holding Brake Specifications* <sup>4</sup>	Rated Voltage	V	24 VDC $^{+10\%}_0$				
	Capacity	W	10				18.5
	Holding Torque	N·m	4.5	12.7	19.6		43.1
	Coil Resistance	$\Omega$ (at 20°C)	56	59			31
	Rated Current	A (at 20°C)	0.43	0.41			0.77
	Time Required to Release Brake	ms	100				170
	Time Required to Brake	ms	80				100
Allowable Load Moment of Inertia (Motor Moment of Inertia Ratio)* <sup>5</sup>	Standard	8 times	2 times	4 times	3 times	2 times	5 times* <sup>7</sup>
	With External Regenerative Resistor or Dynamic Brake Resistor Connected	15 times	4 times	7 times* <sup>7</sup>	6 times* <sup>7</sup>	6 times* <sup>7</sup>	
Allowable Shaft Loads* <sup>6</sup>	LF	mm	40	58			79
	Allowable Radial Load	N	490		686	980	1470
	Allowable Thrust Load	N	98		343	392	490

Note: The values in parentheses are for Servomotors with Holding Brakes.

\*1. These values are for operation in combination with a SERVOPACK when the temperature of the armature winding is 20°C. These are typical values.

\*2. The rated torques are the continuous allowable torque values with an aluminum or steel heat sink of the dimensions given in the table.

## 5.2 Specifications and Ratings

---

### 5.2.2 Servomotor Ratings

- \*3. This does not apply to the shaft opening. Protective structure specifications apply only when the special cable is used.
- \*4. Observe the following precautions if you use a Servomotor with a Holding Brake.
  - The holding brake cannot be used to stop the Servomotor.
  - The time required to release the brake and the time required to brake depend on which discharge circuit is used. Confirm that the operation delay time is appropriate for the actual equipment.
  - The 24-VDC power supply is not provided by Yaskawa.
- \*5. The motor moment of inertia scaling factor is the value for a standard Servomotor without a Holding Brake.
- \*6. The allowable shaft loads are illustrated in the following figure. Design the mechanical system so that the thrust and radial loads applied to the Servomotor shaft end during operation do not exceed the values given in the table.

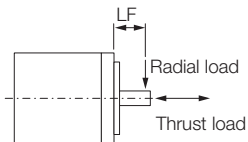

- \*7. When the Tuning-less function is enabled, the Servomotor may vibrate even if it does not exceed the allowable load moment of inertia.

## 5.2.3 Motor Speed-Torque Characteristics

### Standard Servomotors

A : Continuous duty zone  
B : Intermittent duty zone

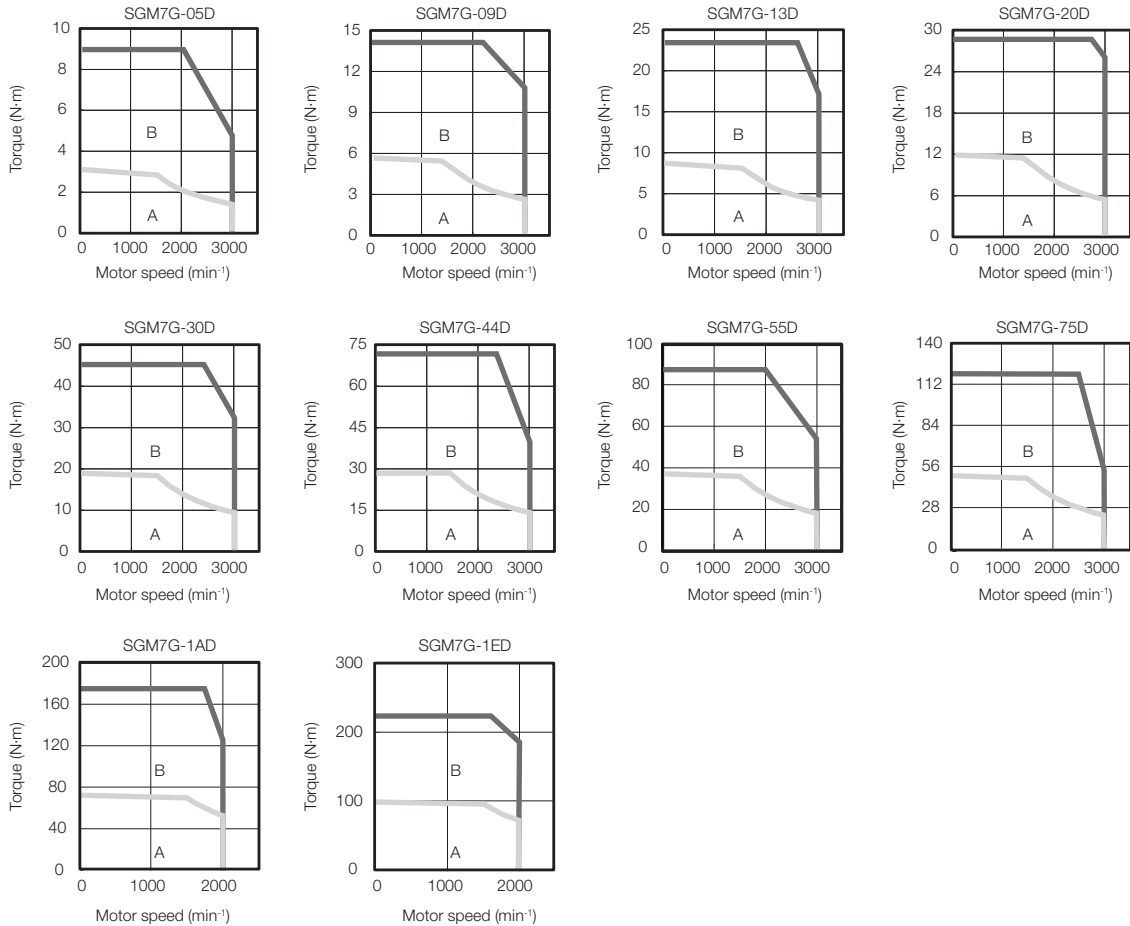

- Note: 1. These values are for operation in combination with a SERVOPACK when the temperature of the armature winding is 20°C. These are typical values.
2. The characteristics in the intermittent duty zone depend on the power supply voltage. The intermittent duty zones in the graphs show the characteristics when a three-phase, 400-VAC power supply voltage is used.
3. If the effective torque is within the allowable range for the rated torque, the Servomotor can be used within the intermittent duty zone.
4. If you use a Servomotor Main Circuit Cable that exceeds 20 m, the intermittent duty zone in the torque-motor speed characteristics will become smaller because the voltage drop increases.

## High-speed Servomotors

**A** : Continuous duty zone

**B** : Intermittent duty zone

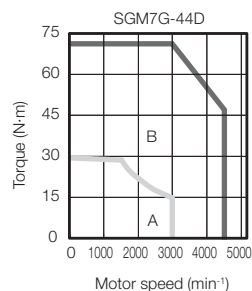
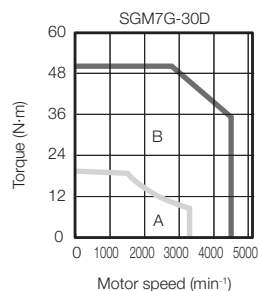
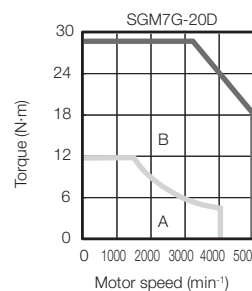
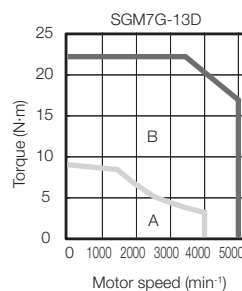
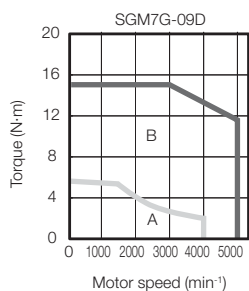
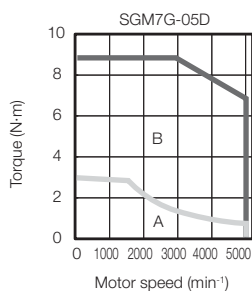

- Note: 1. These values are for operation in combination with a SERVOPACK when the temperature of the armature winding is 20°C. These are typical values.
2. The characteristics in the intermittent duty zone depend on the power supply voltage. The intermittent duty zones in the graphs show the characteristics when a three-phase, 400-VAC power supply voltage is used.
3. If the effective torque is within the allowable range for the rated torque, the Servomotor can be used within the intermittent duty zone.
4. If you use a Servomotor Main Circuit Cable that exceeds 20 m, the intermittent duty zone in the torque-motor speed characteristics will become smaller because the voltage drop increases.

## 5.2.4 Servomotor Overload Protection Characteristics

The overload detection level is set for hot start conditions with a Servomotor surrounding air temperature of 40°C.

### Standard Servomotors

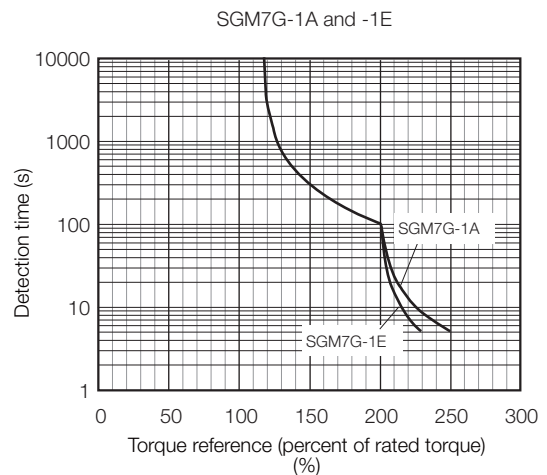
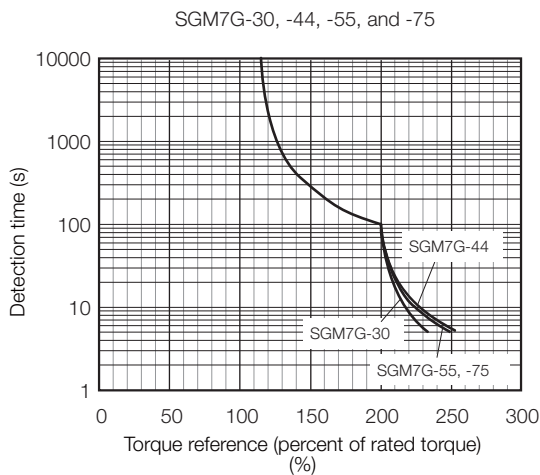
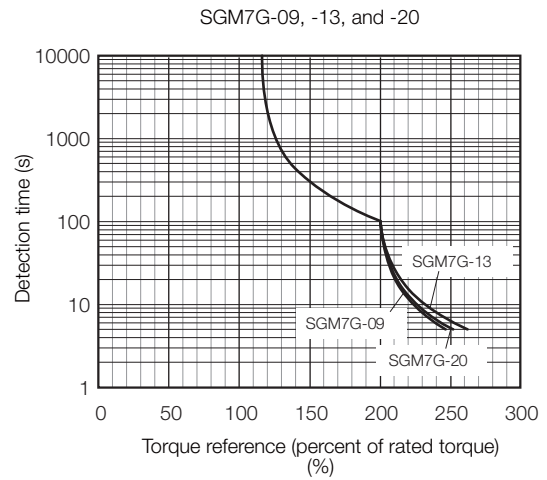
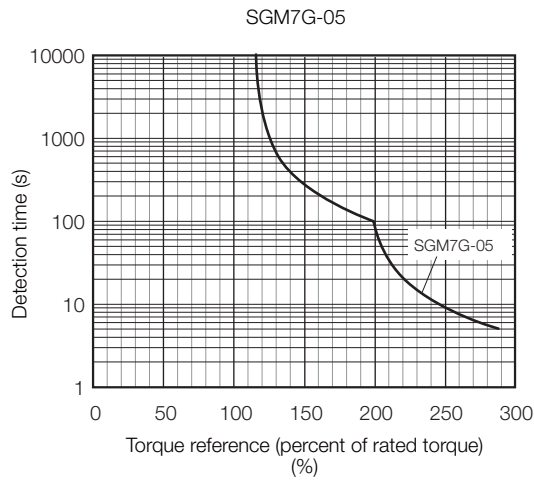

Note: The above overload protection characteristics do not mean that you can perform continuous duty operation with an output of 100% or higher. Use the Servomotor so that the effective torque remains within the continuous duty zone given in 5.2.3 Motor Speed-Torque Characteristics on page 5-9.

## High-speed Servomotors

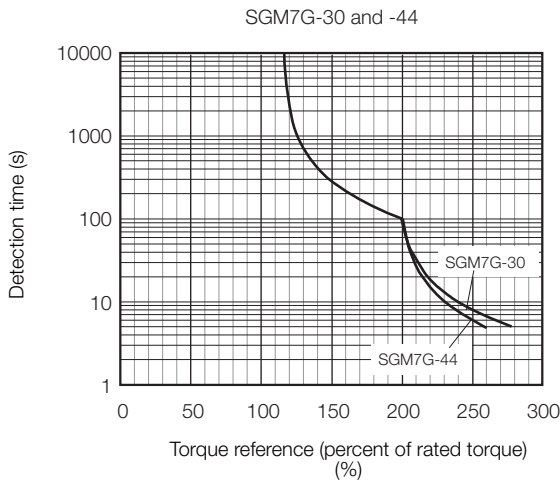
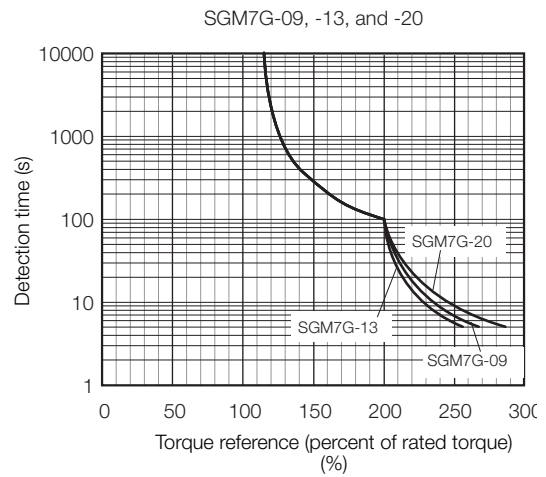
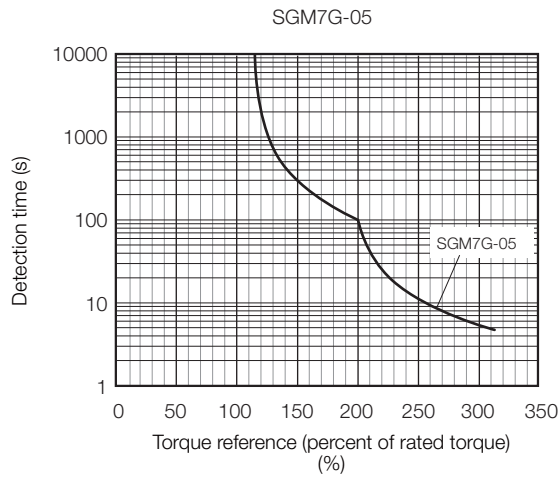

Note: The above overload protection characteristics do not mean that you can perform continuous duty operation with an output of 100% or higher. Use the Servomotor so that the effective torque remains within the continuous duty zone given in 5.2.3 *Motor Speed-Torque Characteristics* on page 5-9.

## 5.2.5 Load Moment of Inertia

The load moment of inertia indicates the inertia of the load. The larger the load moment of inertia, the worse the response. If the moment of inertia is too large, operation will become unstable.

The allowable size of the load moment of inertia ( $J_L$ ) for the Servomotor is restricted. Refer to 5.2.2 *Servomotor Ratings* on page 5-5. This value is provided strictly as a guideline and results depend on Servomotor driving conditions.

An Overvoltage Alarm (A.400) is likely to occur during deceleration if the load moment of inertia exceeds the allowable load moment of inertia. SERVOPACKs with a built-in regenerative resistor may generate a Regenerative Overload Alarm (A.320). Perform one of the following steps if this occurs.

- Reduce the torque limit.
- Reduce the deceleration rate.
- Reduce the maximum motor speed.
- Install an external regenerative resistor if the alarm cannot be cleared using the above steps.

## 5.2.6 Servomotor Heat Dissipation Conditions

The Servomotor ratings are the continuous allowable values when a heat sink is installed on the Servomotor. If the Servomotor is mounted on a small device component, the Servomotor temperature may rise considerably because the surface for heat dissipation becomes smaller. Refer to the following graphs for the relation between the heat sink size and derating rate.

Also, change the overload warning and overload alarm detection timing in advance based on the overload detection level of the motor. Refer to the following section for the overload detection level of the motor.

 5.2.4 Servomotor Overload Protection Characteristics on page 5-11

Note: The derating rates are applicable only when the average motor speed is less than or equal to the rated motor speed. If the average motor speed exceeds the rated motor speed, consult with your Yaskawa representative.



The actual temperature rise depends on how the heat sink (i.e., the Servomotor mounting section) is attached to the installation surface, what material is used for the Servomotor mounting section, and the motor speed. Always check the Servomotor temperature with the actual equipment.

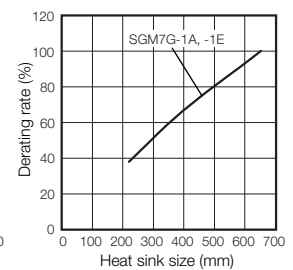
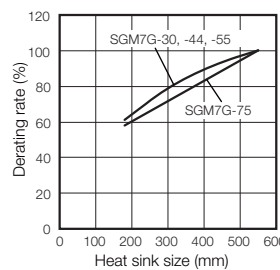
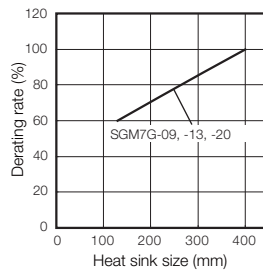
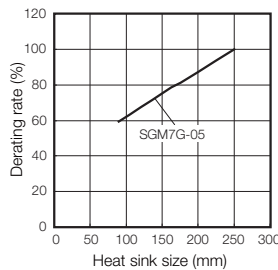

## 5.2.7 Servomotor Derating Rates for Surrounding Air Temperatures

Refer to the following graphs for information on Servomotor derating rates for surrounding air temperatures (60°C max.).

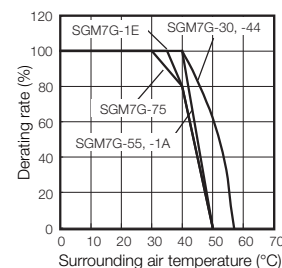
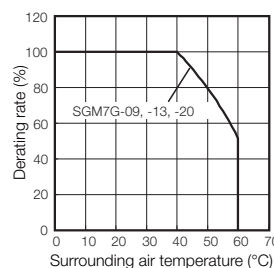
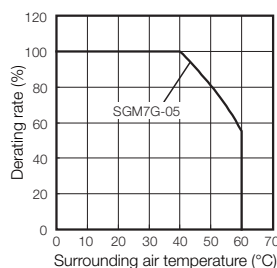

Note: 1. Use the combination of the SERVOPACK and Servomotor so that the derating conditions are satisfied for both the SERVOPACK and Servomotor.

2. The derating rates are applicable only when the average motor speed is less than or equal to the rated motor speed. If the average motor speed exceeds the rated motor speed, consult with your Yaskawa representative.

Also, change the overload warning and overload alarm detection timing in advance based on the overload detection level of the motor. Refer to the following section for the overload detection level of the motor.

 5.2.4 Servomotor Overload Protection Characteristics on page 5-11



## 5.2.8 Applications Where the Altitude of the Servomotor Exceeds 1,000 m

The Servomotor ratings are the continuous allowable values at an altitude of 1,000 m or less. If you use a Servomotor at an altitude that exceeds 1,000 m (2,000 m max.), the heat dissipation effect of the air is reduced. Apply the appropriate derating rate from the following graphs.

Also, change the overload warning and overload alarm detection timing in advance based on the overload detection level of the motor. Refer to the following section for the overload detection level of the motor.

### 5.2.4 Servomotor Overload Protection Characteristics on page 5-11

Note: 1. Use the combination of the SERVOPACK and Servomotor so that the derating conditions are satisfied for both the SERVOPACK and Servomotor.

2. The derating rates are applicable only when the average motor speed is less than or equal to the rated motor speed. If the average motor speed exceeds the rated motor speed, consult with your Yaskawa representative.

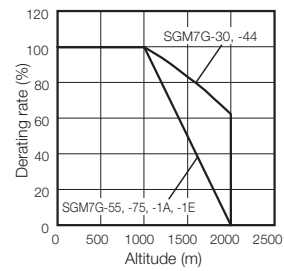
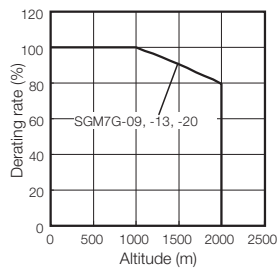
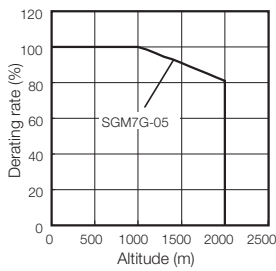

# 5.3 External Dimensions

## 5.3.1 Servomotors

### SGM7G-05

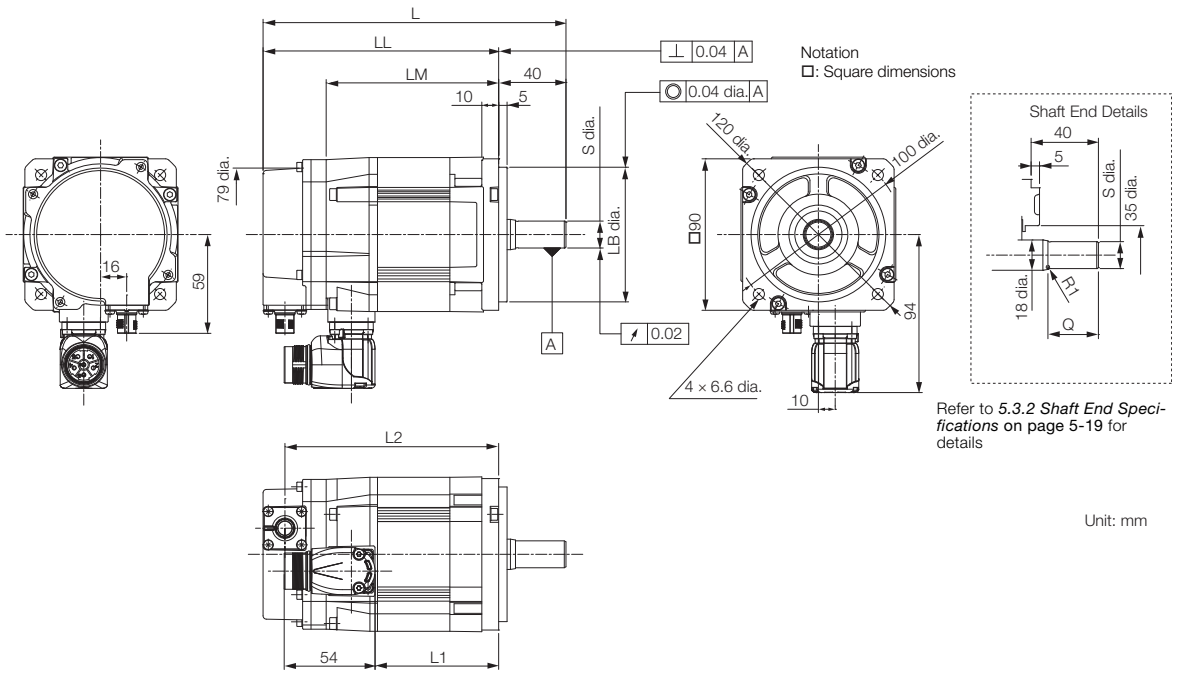

Unit: mm

Model SGM7G-	L	LL	LM	L1	L2	LB	Shaft End Dimensions		Approx. Mass [kg]
							S	Q	
05D□□2□	181 (214)	141 (174)	103 (136)	74	127 (161)	80 <sup>0</sup> <sub>-0.030</sub>	16 <sup>0</sup> <sub>-0.011</sub>	30	3.3 (4.3)

Note: 1. The values in parentheses are for Servomotors with Holding Brakes.  
 2. Servomotors with Dust Seals have the same dimensions.

Refer to the following section for information on connectors.

☞ SGM7G-05D□F to -44D□F and SGM7G-05D□R to -30D□R on page 5-20

### SGM7G-09, -13, and -20

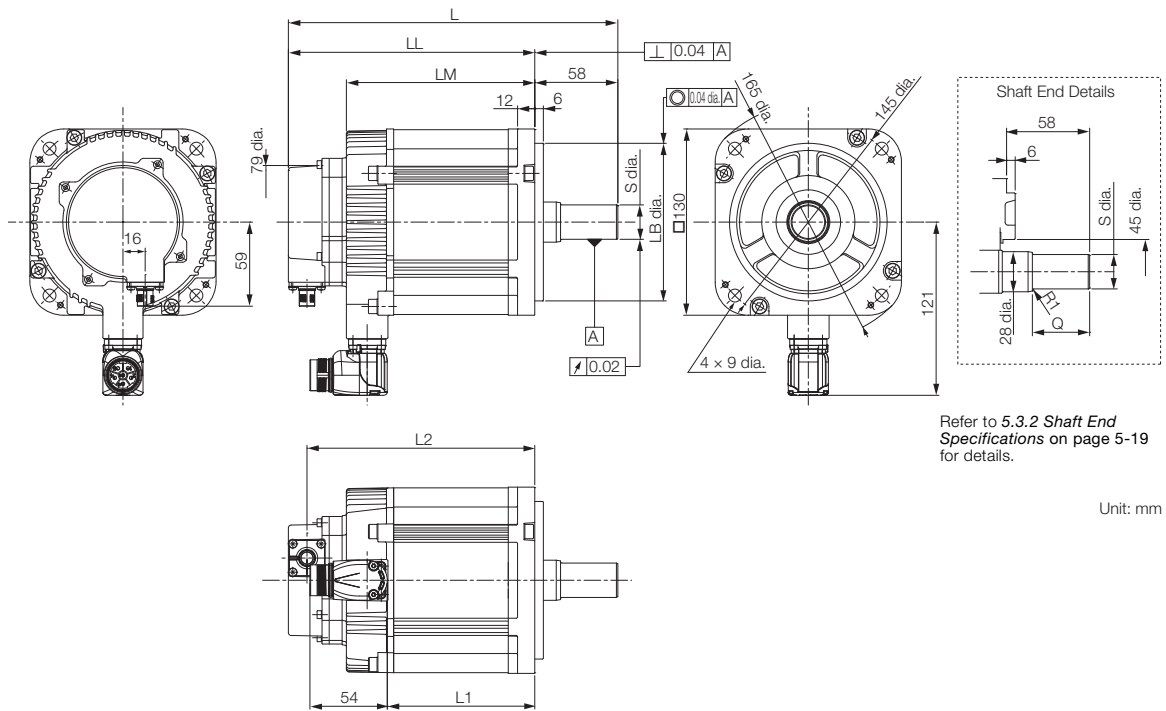

Model SGM7G-	L	LL	LM	L1	L2	LB	Shaft End Dimensions		Approx. Mass [kg]
							S	Q	
09D□□S□	197 (233)	139 (175)	101 (137)	69	125 (161)	110 <sup>0</sup> <sub>-0.035</sub>	19 <sup>0</sup> <sub>-0.013</sub>	40	5.6 (7.6)
13D□□S□	213 (249)	155 (191)	117 (153)	85	141 (177)	110 <sup>0</sup> <sub>-0.035</sub>	22 <sup>0</sup> <sub>-0.013</sub>	40	7.2 (9.1)
20D□□2□	231 (267)	173 (209)	135 (171)	103	159 (195)	110 <sup>0</sup> <sub>-0.035</sub>	24 <sup>0</sup> <sub>-0.013</sub>	40	8.7 (11.1)

Note: 1. The values in parentheses are for Servomotors with Holding Brakes.  
 2. Servomotors with Dust Seals have the same dimensions.

Refer to the following section for information on connectors.

☞ SGM7G-05D□F to -44D□F and SGM7G-05D□R to -30D□R on page 5-20

## SGM7G-30, -44, -55, and -75

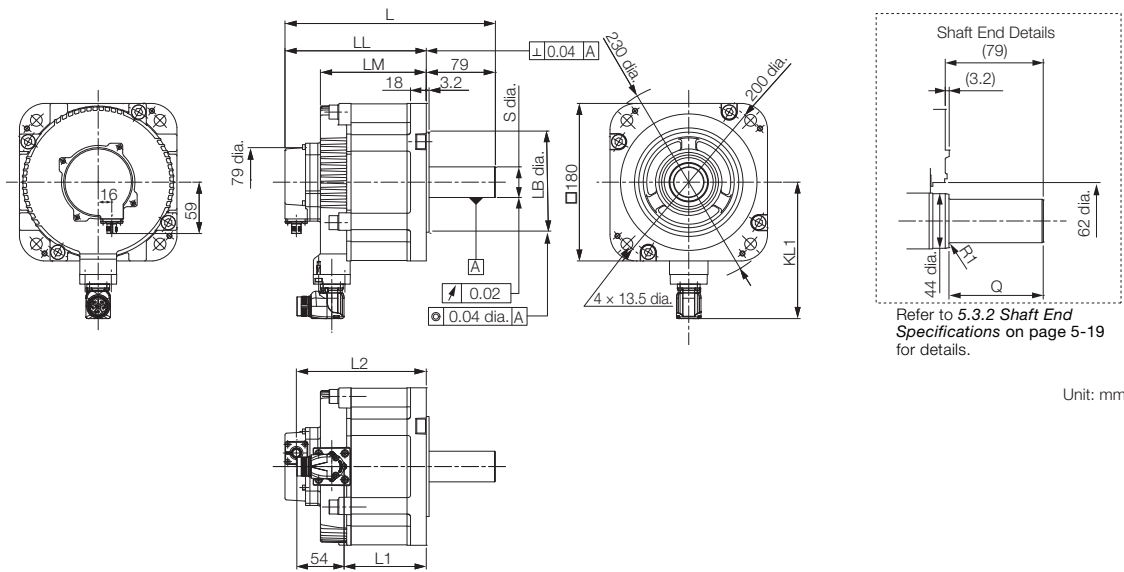

Refer to 5.3.2 Shaft End Specifications on page 5-19 for details.

Unit: mm

Model SGM7G-	L	LL	LM	L1	L2	LB	KL1	Shaft End Dimensions		Approx. Mass [kg]
								S	Q	
30D□□2□	241 (289)	162 (210)	124 (172)	94	149 (197)	114.3 <sup>0</sup> <sub>-0.035</sub>	156	35 <sup>+0.01</sup> <sub>0</sub>	76	13.6 (19.6)
44D□F2□	265 (313)	186 (234)	148 (196)	118	173 (221)	114.3 <sup>0</sup> <sub>-0.025</sub>	156	35 <sup>+0.01</sup> <sub>0</sub>	76	18.0 (24.0)
44D□R2□	265 (313)	186 (234)	148 (196)	112	173 (221)	114.3 <sup>0</sup> <sub>-0.025</sub>	168	35 <sup>+0.01</sup> <sub>0</sub>	76	18.0 (24.0)
55D□F2□	336 (380)	223 (267)	185 (229)	143	210 (254)	114.3 <sup>0</sup> <sub>-0.025</sub>	169	42 <sup>0</sup> <sub>-0.016</sub>	110	22.0 (28.0)
75D□F2□	382 (426)	269 (313)	231 (275)	189	256 (300)	114.3 <sup>0</sup> <sub>-0.025</sub>	169	42 <sup>0</sup> <sub>-0.016</sub>	110	30.0 (35.5)

Note: 1. The values in parentheses are for Servomotors with Holding Brakes.  
 2. Servomotors with Dust Seals have the same dimensions.

Refer to the following section for information on connectors.

☞ SGM7G-05D□F to -44D□F and SGM7G-05D□R to -30D□R on page 5-20

☞ SGM7G-55D□F to -1ED□F and SGM7G-44D□R on page 5-20

### SGM7G-1A and -1E

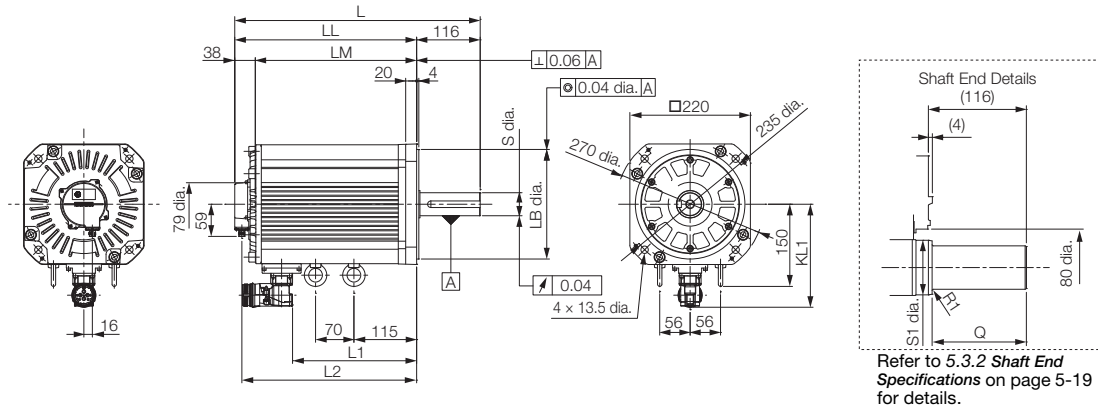

Unit: mm

Model SGM7G-	L	LL	LM	L1	L2	LB	KL1	Shaft End Dimensions			Approx. Mass [kg]
								S	S1	Q	
1AD□F2□	449 (500)	333 (384)	295 (346)	227	319 (371)	200 <sup>0</sup> <sub>-0.046</sub>	188	42 <sup>0</sup> <sub>-0.016</sub>	50	110	57.5 (65.5)
1ED□F2□	511 (600)	395 (484)	357 (446)	289	382 (470)	200 <sup>0</sup> <sub>-0.046</sub>	188	55 <sup>+0.030</sup> <sub>+0.011</sub>	60	110	67.5 (79.5)

Note: 1. The values in parentheses are for Servomotors with Holding Brakes.  
 2. Servomotors with Dust Seals have the same dimensions.

Refer to the following section for information on connectors.

☞ SGM7G-55D□F to -1ED□F and SGM7G-44D□R on page 5-20

## 5.3.2 Shaft End Specifications

### SGM7G-□□□□□□□□

Code	Specification
2 or S*	Straight without key
6 or K*	Straight with key and tap for one location (Key slot is JIS B1301-1996 fastening type.)

Shaft End Details	Servomotor Model: SGM7G-									
	05	09	13	20	30	44	55	75	1A	1E

Code: 2 or S\* (Straight without Key)

	LR	40	58	58	58	79	113	116	
	Q	30	40	40	40	76	110	110	
	S	16 <sup>0</sup> <sub>-0.011</sub>	19 <sup>0</sup> <sub>-0.013</sub>	22 <sup>0</sup> <sub>-0.013</sub>	24 <sup>0</sup> <sub>-0.013</sub>	35 <sup>+0.01</sup> <sub>0</sub>	42 <sup>0</sup> <sub>-0.016</sub>	42 <sup>0</sup> <sub>-0.016</sub>	55 <sup>+0.030</sup> <sub>+0.011</sub>

Code: 6 or K\* (Straight with Key and Tap)

	LR	40	58	58	58	79	113	116	
	Q	30	40	40	40	76	110	110	
	QK	20	25	25	25	60	90	90	
	S	16 <sup>0</sup> <sub>-0.011</sub>	19 <sup>0</sup> <sub>-0.013</sub>	22 <sup>0</sup> <sub>-0.013</sub>	24 <sup>0</sup> <sub>-0.013</sub>	35 <sup>+0.01</sup> <sub>0</sub>	42 <sup>0</sup> <sub>-0.016</sub>	42 <sup>0</sup> <sub>-0.016</sub>	55 <sup>+0.030</sup> <sub>+0.011</sub>
	W	5	5	6	8	10	12	12	16
	T	5	5	6	7	8	8	8	10
	U	3	3	3.5	4	5	5	5	6
	P	M5 screw, Depth: 12				M12 screw, Depth: 25	M16 × 32L	M16 × 32L	M20 × 40L

\* The code for the shaft end depends on the model.  
 SGM7G-05, -20, -30, -44, -55, -75, -1A, or -1E: 2 or 6  
 SGM7G-09 or -13: S or K

## 5.3.3 Connector Specifications

### SGM7G-05D□F to -44D□F and SGM7G-05D□R to -30D□R

• Encoder Connector Specifications

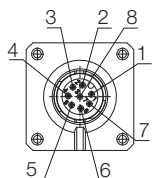

Receptacle  
 Size: M12  
 Part number: 1419959  
 Model: SACC-MSQ-M12MS-25-3,2 SCO  
 Manufacturer: Phoenix Contact

1	PG 5V	6	Data (+)
2	PG 0V	7	Data (-)
3	FG	8	Empty
4	BAT (+)	Housing	Shield
5	BAT (-)		

• Servomotor Connector Specifications

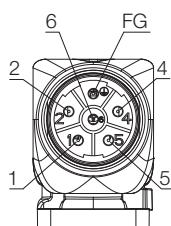

Receptacle  
 Size: M23  
 Part number: 1617905  
 Model: ST-5EP1N8AAD00S  
 Manufacturer: Phoenix Contact

1	V	6	W
2	(Brake)	FG	FG
4	(Brake)	Housing	Shield
5	U		

### SGM7G-55D□F to -1ED□F and SGM7G-44D□R

• Encoder Connector Specifications

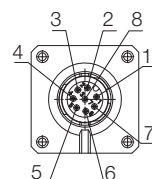

Receptacle  
 Size: M12  
 Part number: 1419959  
 Model: SACC-MSQ-M12MS-25-3,2 SCO  
 Manufacturer: Phoenix Contact

1	PG 5V	6	Data (+)
2	PG 0V	7	Data (-)
3	FG	8	Empty
4	BAT (+)	Housing	Shield
5	BAT (-)		

• Servomotor Connector Specifications

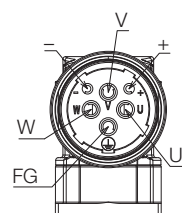

Receptacle  
 Size: M40  
 Part number: 1607927  
 Model: SM-5EPWN8AAD00S  
 Manufacturer: Phoenix Contact

U	U	7	(Brake)
V	V	FG	FG
W	W	Housing	Shield
+	(Brake)		

### Servomotor Connector Rotational Angle

Allowable number of rotations: 10

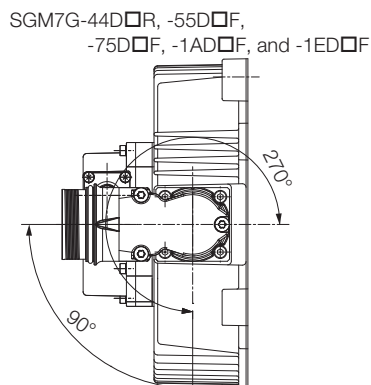
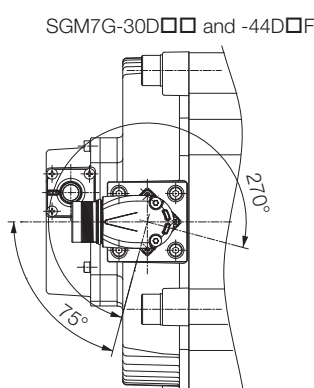
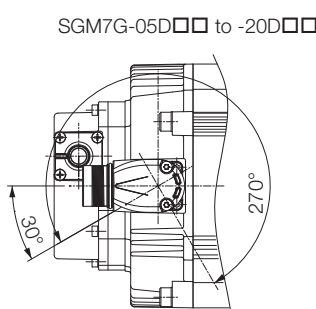

# Servomotor Installation

---

# 6

This chapter describes the installation conditions, procedures, and precautions for Servomotors.

<b>6.1</b>	<b>Installation Conditions</b>	<b>6-2</b>
6.1.1	Installation Precautions	6-2
6.1.2	Installation Environment	6-3
6.1.3	Installation Orientation	6-3
6.1.4	Using Servomotors with Holding Brakes	6-3
<b>6.2</b>	<b>Coupling to the Machine</b>	<b>6-4</b>
6.2.1	Using a Coupling	6-4
6.2.2	Using a Belt	6-5
<b>6.3</b>	<b>Oil and Water Countermeasures</b>	<b>6-7</b>
<b>6.4</b>	<b>Servomotor Temperature Increase</b>	<b>6-8</b>



## 6.1 Installation Conditions

The service life of a Servomotor will be shortened or unexpected problems will occur if the Servomotor is installed incorrectly or in an inappropriate environment or location. Always observe the following installation instructions.

### 6.1.1 Installation Precautions

- Use the lifting bolts on the Servomotor to move only the Servomotor. Never use the lifting bolts on the Servomotor to move the Servomotor while it is installed on the machine. There is a risk of damage to the Servomotor or injury.
- Do not over-tighten the lifting bolts. If you use a tool to over-tighten the lifting bolts, the tapped holes may be damaged.
- Do not hold onto the cables or motor shaft when you move the Servomotor. Doing so may result in injury or damage.
- Do not install the Servomotor in the following locations. Doing so may result in fire, electric shock, or damage.
  - Outdoors or in locations subject to direct sunlight
  - Locations subject to condensation as the result of extreme changes in temperature
  - Locations subject to corrosive or flammable gases or near flammable objects
  - Locations subject to dust, salts, or iron dust
  - Locations subject to oil drops or chemicals
  - Locations subject to shock or vibration
  - Locations that would make it difficult to inspect or clean the Servomotor
- Mount the Servomotor to the machine so that the cables and connectors are not subjected to stress.
- Implement suitable countermeasures, such as attaching a cover, if the Servomotor is used in an application where it is subject to excessive water or oil drops. We recommend that you keep the connectors facing downward.
- Do not connect a Servomotor with an Absolute Encoder in a location where there is a magnetic field with a magnetic flux density of 0.01 tesla (100 gauss) or higher.
- Mount the Servomotor securely to the machine. If the Servomotor is not mounted securely, the machine may be damaged or injury may occur.
- Do not step on or place a heavy object on the Servomotor. Doing so may result in injury.
- Do not allow any foreign matter to enter the Servomotor.
- For a Servomotor with a Cooling Fan, provide at least 200 mm of space around the fan inlet.
- To prevent electric shock, ground the Servomotor securely.
- Servomotors are precision devices. Never drop the Servomotor or subject it to strong shock.
- Implement safety measures, such as installing a cover, so that the motor shaft and other rotating parts of the Servomotor cannot be touched during operation.
- Continuous operation in one direction, such as for a fan, may damage the bearings due to electrolytic corrosion. Contact your Yaskawa representative if you use a Servomotor for this type of application.
- A Servomotor that has been stored for a long period of time must be inspected before it is used. Contact your Yaskawa representative for more information.
- Using a Servomotor for oscillating rotation may reduce the service life of the bearings. (Oscillating rotation is defined as a continuous forward-reverse operation within a 150° rotation angle of the motor shaft.) Rotate the Servomotor one full turn or more at least once a day.
- Never attempt to disassemble or modify a Servomotor.

## 6.1.2 Installation Environment

Refer to the specifications for each type of Servomotor for the mechanical specifications, protective structure, and environmental conditions related to Servomotor installation.

## 6.1.3 Installation Orientation

You can install the Servomotor either horizontally or vertically.

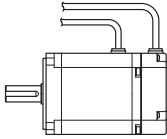
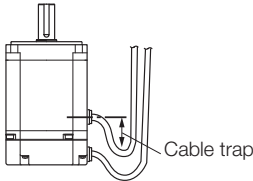
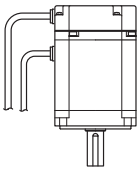
Installation Orientation		Figure	Precautions
Horizontal			—
Vertical	Shaft end up		<ul style="list-style-type: none"> <li>• Provide a cable trap so that water drops will not run into the Servomotor.</li> <li>• Implement countermeasures in the machine so that oil, e.g., from a gear box, does not enter the Servomotor.</li> </ul>
	Shaft end down		—

**Information** If you attach a gear to the Servomotor, observe the installation orientation specified by the manufacturer of the gear.

## 6.1.4 Using Servomotors with Holding Brakes

This section gives precautions for using Servomotors with Holding Brakes

- The holding brakes have a limited service life. Although the quality and reliability of a holding brake has been sufficiently confirmed, stress factors, such as emergency braking, can result in problems in the holding operation. In applications in which safety is a concern, such as for a load falling on a vertical axis, determine if safety measures are required on the machine, such as adding a redundant fall-prevention mechanism.
- For a Servomotor with a Holding Brake, there is a small amount of rotational play in the motor shaft (1.5° max. initially) because of the backlash in the holding brake, even when the brake power is OFF.
- For a Servomotor with a Holding Brake, the brake's rotating disc may sometimes generate murmur from friction during acceleration, stopping, and low-speed operation.
- If a servomotor with a holding brake performs oscillating operation that does not involve continuous operation, the service life of the holding brake may decrease. For this reason, periodically perform continuous operation, such as by running the motor shaft at the rated motor speed. Contact your Yaskawa representative if you will use a servomotor in an application that is not suited to continuous operation.

## 6.2 Coupling to the Machine

You can couple the Servomotor to the machine with either a coupling or a belt. Use the following procedures.

### 6.2.1 Using a Coupling



Important

- Use a flexible coupling that is designed for Servomotors. We recommend that you use a double-spring coupling, which provides some tolerance in eccentricity and deflection.
- Select a suitable size of coupling for the operating conditions. An inappropriate coupling may cause damage.

1. Wipe off all of the anticorrosive coating from the motor shaft.
2. If you are using a Servomotor with a Key, attach the key enclosed with the Servomotor or the specified size of key to the shaft.



Important

When you attach the key to the motor shaft, do not subject the key groove or shaft to direct shock.

3. Confirm that the centering accuracy is within the specified range using a dial gauge or other means.

If a dial gauge is not available, slide the coupling along both shafts and make adjustments so that it does not catch.

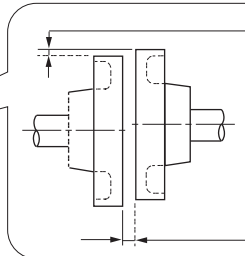
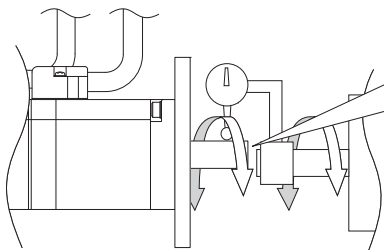

• Centering Accuracy

Measure this distance at four different positions on the circumference. The difference between the maximum and minimum measurements must be 0.03 mm or less. Even within this range, make adjustments to increase centering accuracy as much as possible.

Note: When making the measurements, turn the coupling and motor shaft together.

- Align the shaft of the Servomotor with the shaft of the machine, and then connect the shafts with the coupling.



- When you couple the shafts, make sure that the required centering accuracy is achieved. Vibration will damage the bearings and encoders if the shafts are not properly centered.
- When you attach the coupling, do not subject the shaft to direct shock. Also, do not subject the area around the encoder to shock. Shock may damage the encoder.

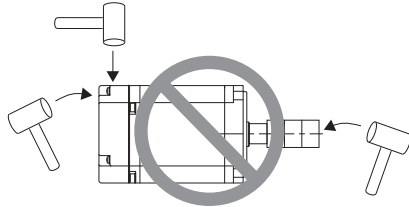

- If the coupling makes any abnormal noise, center the shafts again until the noise is eliminated.
- Make sure that the thrust load and radial load are within specifications. Refer to the specifications for each type of Servomotor for the thrust load and radial load.

## 6.2.2 Using a Belt



Select a coupling belt that is suitable for the allowable radial load of the Servomotor and the Servomotor output. When the Servomotor accelerates or decelerates, the counterforce from the acceleration/deceleration torque adds tension to the initial belt tension. Take this additional tension into consideration when you select the coupling belt.

- Wipe off all of the anticorrosive coating from the motor shaft.
- If you are using a Servomotor with a Key, attach the key enclosed with the Servomotor or the specified size of key to the shaft.



When you attach the key to the motor shaft, do not subject the key groove or shaft to direct shock.

- If you need to attach a pulley to the Servomotor with a Key, use a screwdriver to tighten the screw in the end of the motor shaft to press in and attach the pulley.

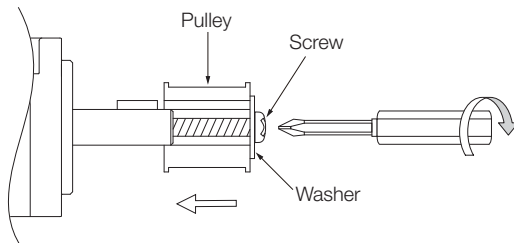

**4. Couple the Servomotor to the machine with a belt.**

When you attach the belt, adjust the belt tension so that the allowable radial load given in the Servomotor specifications is not exceeded. For details, refer to the catalog of the belt manufacturer.

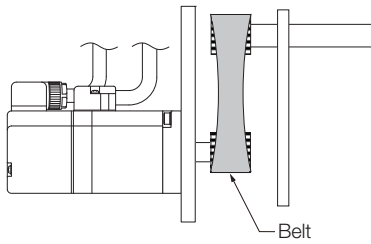

Important

Adjust the belt tension to adjust the radial load. Measure the belt tension at 45° intervals of the machine shaft. Turn the shaft and take measurements with a belt tension meter at each point.

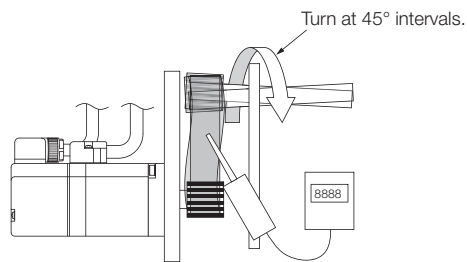

## 6.3 Oil and Water Countermeasures

Observe the following instructions so that water, oil, or other foreign matter will not enter the Servomotor.

- Do not allow the cables to be in oil or water.

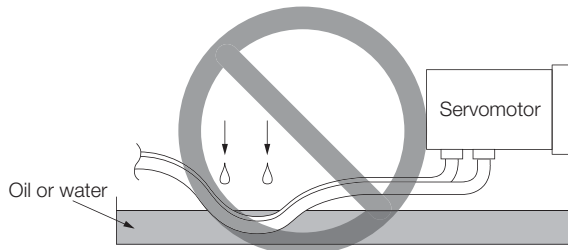

If contact with oil or water is unavoidable, use oil-resistant cables. Oil-resistant cables are not provided by Yaskawa.

- If you install the Servomotor with the end of the shaft facing up, do not use the Servomotor where oil or water from the machine, a gear box, or other source would come into contact with the Servomotor.

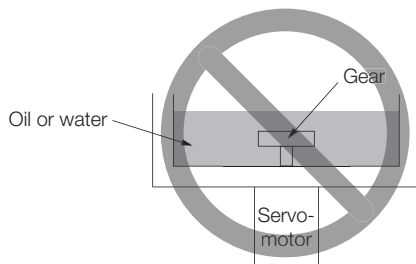

If contact with oil or water is unavoidable, implement countermeasures in the machine so that oil from the gear box does not enter the Servomotor.

- Do not use the Servomotor where it would come into contact with cutting fluids. Depending on the type of cutting fluid, sealing materials, packing, cables, or other parts may be adversely affected.
- Do not use the Servomotor where it would be continuously in contact with oil mist, water vapor, oil, water, or grease. If usage under the above conditions is unavoidable, implement countermeasures in the machine to protect against dirt and water.

## 6.4 Servomotor Temperature Increase

This section describes measures to suppress temperature increases in the Servomotor.

- When you install the Servomotor, observe the cooling conditions (heat sink sizes) that are given in the specifications for each type of Servomotor.

The Servomotor generates heat when it operates. The heat generated by the Servomotor radiates to the heat sink through the motor mounting surface. Therefore, if the surface area of the heat sink is too small, the temperature of the Servomotor may increase abnormally.

- If the operating environment makes it difficult to use a large heat sink, or if the surrounding air temperature or altitude given in the specifications is exceeded, implement the following measures.
  - Derate the Servomotor.  
Refer to the specifications for each type of Servomotor for information on derating.  
Consider derating when you select the capacity of the Servomotor.
  - Use external forced-air cooling for the Servomotor with a cooling fan or other means.



Important

Do not place packing or any other insulating material between the Servomotor and heat sink. Doing so will cause the motor temperature to increase, affect resistance to noise, and may cause motor failure.

# Connections between Servomotors and SERVOPACKs

---



This chapter provides precautions on connecting the Servomotors and SERVOPACKs.

## **7.1** Wiring Servomotors and SERVOPACKs . . . 7-2

7.1.1	Wiring Precautions . . . . .	7-2
-------	------------------------------	-----



## 7.1 Wiring Servomotors and SERVOPACKs

### 7.1.1 Wiring Precautions



#### CAUTION

- Do not connect the Servomotor directly to an industrial power supply. Doing so will destroy the Servomotor. You cannot operate a Servomotor without a SERVOPACK that is designed for it.

#### General Precautions

- Never perform any wiring work while the power supply is ON.
- Always connect the Servomotor Main Circuit Cable before you connect the Encoder Cable. If you connect the Encoder Cable first, the encoder may be damaged due to the difference in electrical potential from the FG.
- Never touch the connector pins on the Servomotor directly with your hands. Particularly the encoder may be damaged by static electricity.
- Do not remove rubber packings or O-rings. Also, make sure that rubber packings and O-rings do not come off. If the rubber packings or O-rings are not securely attached, the protective structure specifications may not be satisfied.
- Separate the Servomotor Main Circuit Cable from the I/O Signal Cables and Encoder Cable by at least 30 cm.
- Do not connect magnetic contactors, reactors, or other devices on the cables that connect the SERVOPACK and Servomotor. Failure to observe this caution may result in malfunction or damage.
- Do not subject the cables to excessive bending stress or tension. The conductors in the Encoder Cable and Servomotor Main Circuit Cable are as thin as 0.2 mm<sup>2</sup> or 0.3 mm<sup>2</sup>. Wire them so that they are not subjected to excessive stress.
- If you secure the cables with cable ties, protect the cables with cushioning material.
- If the cable will be bent repeatedly, e.g., if the Servomotor will move in the machine, use Flexible Cables. If you do not use Flexible Cables, the cables may break.
- Before you connect the wires, make sure that there are no mistakes in the wiring.
- Always use the connectors specified by Yaskawa and insert them correctly.
- When you connect a connector, check it to make sure there is no foreign matter, such as metal clippings, inside.
- The connectors are made of resin. To prevent damage, do not apply any strong impact.
- Perform all wiring so that stress is not applied to the connectors. The connectors may break if they are subjected to stress.
- If you move the Servomotor while the cables are connected, always hold onto the main body of the Servomotor. If you lift the Servomotor by the cables when you move it, the connectors may be damaged or the cables may be broken.

## Grounding Precautions

The ground terminal on the SERVOPACK is used to ground the Servomotor.

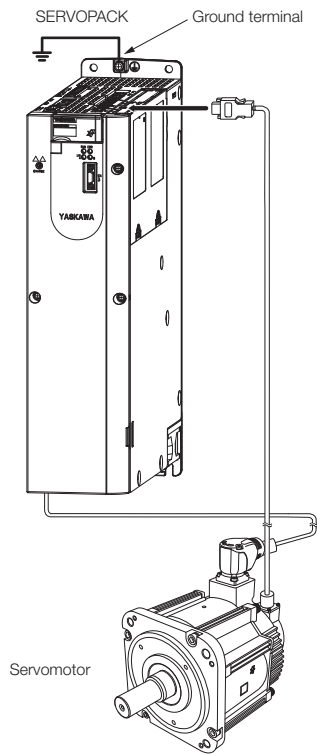

# Maintenance and Inspection

---



This chapter describes the maintenance, inspection, and disposal of a Servomotor.

<b>8.1</b>	<b>Periodic Inspections . . . . .</b>	<b>8-2</b>
<b>8.2</b>	<b>Service Lives of Parts . . . . .</b>	<b>8-3</b>
<b>8.3</b>	<b>Disposing of Servomotors . . . . .</b>	<b>8-4</b>

# 8.1 Periodic Inspections

The following table gives the periodic inspection items for a Servomotor. The inspection periods given in the table are guidelines. Determine the optimum inspection periods based on the application conditions and environment.

 **CAUTION**

- Before you perform any maintenance or inspection work, turn OFF the power supply, confirm that the CHARGE indicator on the front of the SERVOPACK has gone out, and then use a tester to check the voltage between the positive and negative terminals on the SERVOPACK. Start inspection work only after you have confirmed that the main circuit voltage has dropped.  
If there is any main circuit voltage left, the risk of electric shock still exists. Do not touch the Servomotor or any wiring.
- All inspection and maintenance work must be performed only by qualified engineers. There is a risk of electric shock or injury.
- Contact your Yaskawa representative for help with failures, repairs, or part replacement.

Item	Inspection Period	Basic Inspection and Maintenance Procedure	Remarks
Check the coupling between the Servomotor and the machine.	Before starting operation	<ul style="list-style-type: none"> <li>• Make sure that there are no loose mounting screws between the Servomotor and machine.</li> <li>• Make sure that there is no looseness in the coupling between the Servomotor and machine.</li> <li>• Make sure that there is no misalignment.</li> </ul>	–
Check for vibration and noise.	Daily	Inspect by touching and by listening.	There should be no more vibration or noise than normal.
Exterior	Check for dirt and grime.	Clean off the dirt and grime with a cloth or pressurized air.	–
Measure the insulation resistance.	At least once a year	Disconnect the Servomotor from the SERVOPACK and measure the insulation resistance at 500 V with an insulation resistance meter. (Measurement method: Measure the resistance between phase U, V, or W on the Servomotor's power line and FG.) The insulation is normal if the resistance is 10 MΩ or higher.	If the resistance is less than 10 MΩ, contact your Yaskawa representative.
Overhaul	At least once every 5 years or every 20,000 hours	Contact your Yaskawa representative.	–

## 8.2 Service Lives of Parts

The following table gives the standard service lives of the parts of the Servomotor. Contact your Yaskawa representative using the following table as a guide. After an examination of the part in question, we will determine whether the part should be replaced. Even if the service life of a part has not expired, replacement may be required if abnormalities occur. The standard service lives in the table are only for reference. The actual service lives will depend on the application conditions and environment.

Part	Standard Service Life	Remarks
Bearing	20,000 hours	The service life is affected by operating conditions. Check for abnormal sounds and vibration during inspections.
Holding Brake	20,000 hours	The service life is affected by operating conditions. Check for abnormal sounds and vibration during inspections. Confirm that the brake is released when power is supplied and check for any changes in the operating time of the brake.

## 8.3 Disposing of Servomotors

When disposing of a Servomotor, treat it as ordinary industrial waste. However, local ordinances and national laws must be observed. Implement all labeling and warnings as a final product as required.

# Appendices

---

# 9

The appendices provide information to use when selecting Servomotor capacities.

## **9.1** Reference Information for Servomotor Capacity Selection . . . . 9-2

- 9.1.1 Formulas Required to Select the Servomotor Capacity . . . . . 9-2
- 9.1.2  $GD^2$  for Simple Diagrams . . . . . 9-3
- 9.1.3 Conversions between Engineering Units and SI Units . . . . . 9-4
- 9.1.4 Application Examples by Type of Application . . . 9-5

# 9.1 Reference Information for Servomotor Capacity Selection

## 9.1.1 Formulas Required to Select the Servomotor Capacity

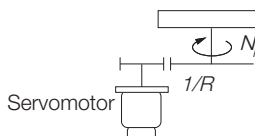
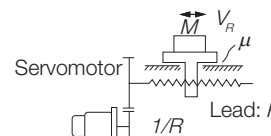
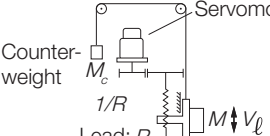
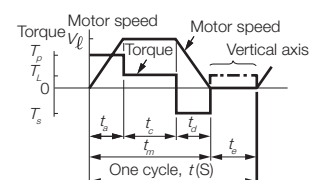
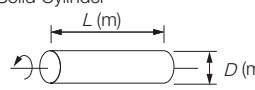
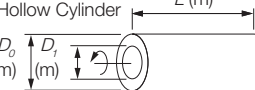
Type of Motion	Rotary Motion	Linear Motion	
		Horizontal Axis	Vertical Axis
Machine Configuration			
	$N_\ell$ : Load shaft speed (min <sup>-1</sup> ) $V_\ell$ : Load speed (m/min) $T_\ell$ : Load torque calculated at load shaft (N·m) $\mu$ : Friction coefficient	$P_B$ : Ball screw lead (m) $M$ : Linear motion section mass (kg) $M_C$ : Counterweight mass (kg)	$1/R$ : Gear ratio $\eta$ : Mechanical efficiency $T_{PM}$ : Servomotor instantaneous maximum torque (N·m)
Speed Diagram			
Travel distance (m)	$R = \frac{V_\ell}{60} \cdot t_a + \frac{2t_c + t_d}{2} \quad \left( t_a = \text{If...}t_d, R... = \frac{V_\ell}{60} (t_m - t_a) \right)$		
Load Shaft Speed (min <sup>-1</sup> )	$N_\ell$	$N_\ell = \frac{V_\ell}{P_B}$	
Motor Shaft Speed (min <sup>-1</sup> )	$N_M = N_\ell \cdot R$		
Load Torque Calculated at Motor Shaft (N·m)	$T_L = \frac{T_\ell}{R \cdot \eta}$	$T_L = \frac{9.8 \times \mu \cdot M \cdot P_B}{2\pi \cdot R \cdot \eta}$	$T_L = \frac{9.8 \times (M - M_C) P_B}{2\pi \cdot R \cdot \eta}$
Load Moment of Inertia Calculated at Motor Shaft (kg·m <sup>2</sup> )	$J_L = J_{L1} + J_{L2} + J_{L3}$		
Linear Motion Section	-	$J_{L1} = M \cdot \left( \frac{P_B}{2\pi R} \right)^2$	$J_{L1} = (M + M_C) \cdot \left( \frac{P_B}{2\pi R} \right)^2$
Rotary Motion Section	<ul style="list-style-type: none"> <li>Solid Cylinder                              </li> <li>Hollow Cylinder                              </li> </ul>	$J_k = \frac{1}{8} M_k \cdot D^2$ OR $J_k = \frac{\pi}{32} \rho \cdot L \cdot D^4$ $M_k$ : Solid cylinder mass (kg) $\rho$ : Density (kg/m <sup>3</sup> )...Iron $\rho = 7.87 \times 10^3$ (kg/m <sup>3</sup> ) ...Aluminum $\rho = 2.70 \times 10^3$ (kg/m <sup>3</sup> )	$J_k = \frac{1}{8} M_k (D_o^2 + D_i^2)$ OR $J_k = \frac{\pi}{32} \rho \cdot L (D_o^4 - D_i^4)$
	Moment of Inertia of Rotary Motion Section Calculated at Motor Shaft Rotary motion section at gear input shaft $J_{L2} = J_k$ Rotary motion section at gear output shaft $J_{L3} = \frac{J_k}{R^2}$		
Minimum Starting Time (s)	$t_{am} = \frac{2\pi \cdot N_M (J_M + J_L)}{60 (T_{PM} - T_L)}$		

Continued on next page.



Continued from previous page.

Type of Motion	Rotary Motion	Linear Motion	
		Horizontal Axis	Vertical Axis
Minimum Braking Time (s)	$t_{dm} = \frac{2\pi \cdot N_M (J_M + J_L)}{60 (T_{PM} + T_L)}$		
Load Moving Power (W)	$P_o = \frac{2\pi \cdot N_M \cdot T_L}{60}$		
Load Acceleration Power (W)	$P_a = \left(\frac{2\pi \cdot N_M}{60}\right)^2 \frac{J_L}{t_a}$	$(t_a \geq t_{am})$	
Required Starting Torque (N·m)	$T_p = \frac{2\pi \cdot N_M (J_M + J_L)}{60 \times t_a} + T_L$	$(t_a \geq t_{am})$	
Required Braking Torque (N·m)	$T_s = \frac{2\pi \cdot N_M (J_M + J_L)}{60 \times t_d} - T_L$	$(t_d \geq t_{dm})$	
Effective Torque Value (N·m)	$T_{rms} = \sqrt{\frac{T_p^2 \cdot t_a + T_L^2 \cdot t_c + T_s^2 \cdot t_d}{t}}$		$T_{rms} = \sqrt{\frac{T_p^2 \cdot t_a + T_L^2 (t_c + t_d) + T_s^2 \cdot t_d}{t}}$

## 9.1.2 GD<sup>2</sup> for Simple Diagrams

When Rotary Shaft Is Aligned with Center Line of Cylinder	Solid cylinder ( $D^2 = D_o^2/2$ )  (OR $GD^2 = 125\pi \rho L D^4$ $\rho$ : Density (g/cm <sup>3</sup> )...Copper: 7.866 $L$ : Length (m) $D$ : Diameter (m))		Hollow cylinder $D^2 = (D_o^2 + D_i^2)/2$  (OR $GD^2 = 125\pi \rho L (D_o^4 + D_i^4)$ $\rho$ : Density (g/cm <sup>3</sup> ) $L$ : Length (m) $D_o, D_i$ : Diameter (m))	
	When Rotary Shaft Runs Through Gravitational Center	Rectangular solid $D^2 = (b^2 + c^2)/3$		Cylindrical body $D^2 = L^2/3 + D_o^2/4$
Sphere $D^2 = \frac{2}{5} D_o^2$			Hollow sphere $D^2 = \frac{2}{5} \cdot \frac{D_o^5 - D_i^3}{D_o^3 - D_i^3}$	
Cone $D^2 = \frac{3}{10} D_o^2$			Wheel $D^2 = D_o^2 + \frac{3}{4} D_i^2$	
When Rotary Shaft Is on One End	Rectangular solid $D^2 = (4b^2 + C^2)/3$		Cylindrical body $D^2 = \frac{4}{3} L^2 + \frac{D_o^2}{4}$	
When Rotary Shaft Is Outside Rotating Body	Rectangular solid $D^2 = \frac{4b^2 + C^2}{3} + 4(bd + d^2)$		Cylindrical body $D^2 = \frac{4}{3} L^2 + \frac{D_o^2}{4} + 4(dL + d^2)$	

Continued on next page.

9.1 Reference Information for Servomotor Capacity Selection

9.1.3 Conversions between Engineering Units and SI Units

Continued from previous page.

General Formula When Rotary Shaft Is outside Rotating Body	<p>General formula for diameter of rotation when rotary shaft is outside rotating body</p> $D_2^2 = D_1^2 + 4 d^2$ <p><math>D_1</math>: Diameter of rotation when shaft that is parallel to rotary shaft and runs through center of gravity virtually operates as a rotary shaft</p>	<p>The diagram shows an irregularly shaped rotating body. A point is marked as the 'Center of gravity'. A vertical line with arrows at both ends passes through this point. A horizontal line, labeled 'Rotary shaft', is positioned below the center of gravity. The vertical distance between the center of gravity and the rotary shaft is labeled 'd'.</p>
------------------------------------------------------------	--------------------------------------------------------------------------------------------------------------------------------------------------------------------------------------------------------------------------------------------------------------------------------------	----------------------------------------------------------------------------------------------------------------------------------------------------------------------------------------------------------------------------------------------------------------------------------------------------------------------------------------------------------------

**Information**  $GD^2 = \text{Weight} \times (\text{Diameter of rotation})^2$

## 9.1.3 Conversions between Engineering Units and SI Units

The following table provides the conversion rates between engineering units and SI units for typical physical quantities required for capacity selection.

Quantity	Engineering Unit	SI Unit	Conversion Factor
Force or load	kgf	N	1 kgf = 9.80665 N
Weight	kgf	-	The numerical values are the same for mass in the traditional unit and the SI unit. (The mass SI unit Wkg is used for objects in the Wkgf traditional unit.)
Mass	kgf·s <sup>2</sup> /m	kg	
Torque	kgf·m	N·m	1 kgf·m = 9.80665 N·m
Inertia (moment of inertia)	gf·cm·s <sup>2</sup>	kg·m <sup>2</sup>	1 gf·cm·s <sup>2</sup> = 0.980665 × 10 <sup>-4</sup> kg·m <sup>2</sup>
GD <sup>2</sup>	kgf·m <sup>2</sup>	kg·m <sup>2</sup>	<p>Relationship between GD<sup>2</sup> (kgf·m<sup>2</sup>) and moment of inertia <math>J</math> (kg·m<sup>2</sup>)</p> $J = \frac{GD^2}{4}$

## 9.1.4 Application Examples by Type of Application

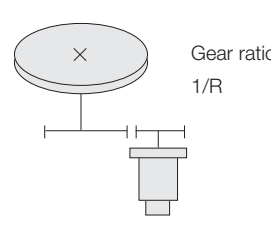
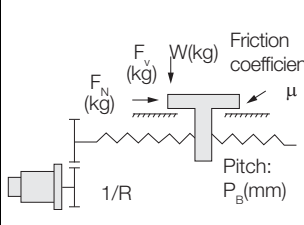
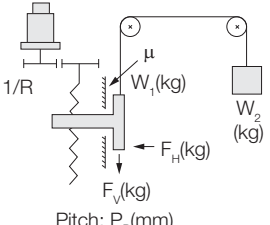
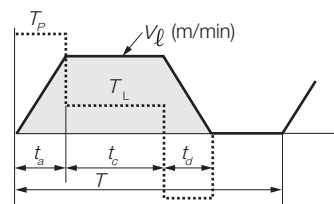
Machine Configuration		Rotating Body	Horizontal Ball Screw	Vertical Ball Screw
				
Load Speed, $N_\ell$ ( $\text{min}^{-1}$ )		$N_\ell$	Load speed (m/min) $\frac{1000 \times V_\ell}{P_B}$	Load speed (m/min) $\frac{1000 \times V_\ell}{P_B}$
Speed Calculated at Motor Shaft, $N_M$ ( $\text{min}^{-1}$ )		$R \times N_\ell$	$R \times N_\ell$	$R \times N_\ell$
Linear Motion Section, $GD_2$ ( $\text{kg} \cdot \text{m}^2$ )	$GD^2_\ell$ Calculated at Load Shaft	-	$W \cdot \left(\frac{P_B}{1000\pi}\right)^2$	$W \cdot \left(\frac{P_B}{1000\pi}\right)^2$ [However, $W=W_1+W_2$ ]
	$GD^2_L$ Calculated at Motor Shaft	$GD^2_L \times \left(\frac{1}{R}\right)^2$	$GD^2_L \times \left(\frac{1}{R}\right)^2$ [OR $W \cdot \left(\frac{V_\ell}{\pi \cdot N_M}\right)^2$ ]	$GD^2_L \times \left(\frac{1}{R}\right)^2$ [OR $W \cdot \left(\frac{V_\ell}{\pi \cdot N_M}\right)^2$ ] [However, $W=W_1+W_2$ ]
Load Torque ( $\text{kg} \cdot \text{m}$ )	$T_\ell$ Calculated at Load Shaft	$T_\ell$	$\{\mu \cdot (W + F_V) + F_H\} \cdot \frac{P_B}{2000\pi}$	$\{\mu \cdot F_H + W_1 - W_2 + F_V\} \cdot \frac{P_B}{2000\pi}$
	$T_L$ Calculated at Motor Shaft	$T_\ell \times \frac{1}{R} \times \frac{1}{\eta}$ Mechanical efficiency	$T_\ell \times \frac{1}{R} \times \frac{1}{\eta}$ ← Mechanical efficiency [OR $\frac{\{\mu \cdot (W + F_V) + F_H\} \cdot V_\ell}{2\pi \cdot N_M \cdot \eta}$ ]	$T_\ell \times \frac{1}{R} \times \frac{1}{\eta}$ ← Mechanical efficiency [OR $\frac{\{\mu \cdot F_H + W_1 - W_2 + F_V\} \cdot V_\ell}{2\pi \cdot N_M \cdot \eta}$ ]
Load Moving Power, $P_O$ (kW)		$\frac{T_\ell \cdot N_\ell}{973 \times \eta}$	$\frac{\{\mu \cdot (W + F_V) + F_H\} \cdot V_\ell}{6120 \times \eta}$	$\frac{\{\mu \cdot F_H + W_1 - W_2 + F_V\} \cdot V_\ell}{6120 \times \eta}$
Load Acceleration Power		$\frac{GD^2_\ell \cdot N_\ell^2}{365 \times 10^3 \times t_a}$ Acceleration time (s)	$\frac{GD^2_\ell \cdot N_\ell^2}{365 \times 10^3 \times t_a}$ Acceleration time (s)	$\frac{GD^2_\ell \cdot N_\ell^2}{365 \times 10^3 \times t_a}$ Acceleration time (s)
Starting Torque, $T_P$ ( $\text{kg} \cdot \text{m}$ ) Deceleration Torque, $T_S$ ( $\text{kg} \cdot \text{m}$ ) Effective Torque Value, $T_{rms}$ ( $\text{kg} \cdot \text{m}$ )			$T_P = \frac{(GD^2_M + GD^2_L) \cdot N_M}{375 \cdot t_a} + T_L$ $T_S = \frac{(GD^2_M + GD^2_L) \cdot N_M}{375 \cdot t_d} - T_L$ $T_{rms} = \sqrt{\frac{T_P^2 \cdot t_a + T_L^2 \cdot t_c + T_S^2 \cdot t_d}{T}}$ <p>[When a load torque is applied while stopped for a vertical ball screw:</p> $T_{rms} = \sqrt{\frac{T_P^2 \cdot t_a + T_L^2 \cdot (T - t_a - t_d) + T_S^2 \cdot t_d}{T}}$	
System Remarks		-	<ul style="list-style-type: none"> <li>The gear backlash is a problem.</li> <li>Suitable for applications for which increasing system speed is not required.</li> <li>A large torque can be generated by a small motor.</li> </ul>	<ul style="list-style-type: none"> <li>Falling when <math>W_1 \neq W_2</math></li> <li>Brake timing</li> </ul>

Continued on next page.

9.1 Reference Information for Servomotor Capacity Selection

9.1.4 Application Examples by Type of Application

Continued from previous page.

Machine Configuration		Roll Feeder	Rack and Pinion
Load Speed, $N_\ell$ ( $\text{min}^{-1}$ )	$\frac{1000 \times V_\ell}{P_B}$ <p>[However, <math>P_B = \pi \cdot d_p</math>]</p>	$\frac{1000 \times V_\ell}{P_B}$ <p>[However, <math>P_B = \pi \cdot d_p</math>] [OR <math>P_B = Z_p \cdot L_p</math>]</p>	
Speed Calculated at Motor Shaft, $N_M$ ( $\text{min}^{-1}$ )	$R \times N_\ell$	$R \times N_\ell$	
Linear Motion Section, $GD_2$ ( $\text{kg} \cdot \text{m}^2$ )	$GD_\ell^2$ Calculated at Load Shaft	$W \cdot \left(\frac{d_p}{1000}\right)^2$	$W \cdot \left(\frac{d_p}{1000}\right)^2$
	$GD_L^2$ Calculated at Motor Shaft	$GD_L^2 \times \left(\frac{1}{R}\right)^2$ [OR $W \cdot \left(\frac{V_\ell}{\pi \cdot N_M}\right)^2$ ]	$GD_L^2 \times \left(\frac{1}{R}\right)^2$ [OR $W \cdot \left(\frac{V_\ell}{\pi \cdot N_M}\right)^2$ ]
Load Torque ( $\text{kg} \cdot \text{m}$ )	$T_\ell$ Calculated at Load Shaft	$(F_t + \mu_1 W + \mu_2 N) \cdot \frac{d_p}{2000}$	$\{\mu \cdot (W + F_v) + F_h\} \cdot \frac{d_p}{2000}$
	$T_L$ Calculated at Motor Shaft	$T_\ell \times \frac{1}{R} \times \frac{1}{\eta}$ ← Mechanical efficiency [OR $\frac{(F_t + \mu_1 W + \mu_2 N) \cdot V_\ell}{2\pi \cdot N_M \cdot \eta}$ ]	$T_\ell \times \frac{1}{R} \times \frac{1}{\eta}$ ← Mechanical efficiency [OR $\frac{\{\mu \cdot (W + F_v) + F_h\} \cdot V_\ell}{2\pi \cdot N_M \cdot \eta}$ ]
Load Moving Power, $P_O$ (kW)	$\frac{(F_t + \mu_1 W + \mu_2 N) \cdot V_\ell}{6120 \times \eta}$	$\frac{\{\mu \cdot (W + F_v) + F_h\} \cdot V_\ell}{6120 \times \eta}$	
Load Acceleration Power	$\frac{GD_\ell^2 \cdot N_\ell^2}{365 \times 10^3 \times t_a}$ ← Acceleration time (s)	$\frac{GD_\ell^2 \cdot N_\ell^2}{365 \times 10^3 \times t_a}$ ← Acceleration time (s)	
Starting Torque, $T_P$ ( $\text{kg} \cdot \text{m}$ ) Deceleration Torque, $T_S$ ( $\text{kg} \cdot \text{m}$ ) Effective Torque Value, $T_{rms}$ ( $\text{kg} \cdot \text{m}$ )		$T_P = \frac{(GD_M^2 + GD_L^2) \cdot N_M}{375 \cdot t_a} + T_L$ $T_S = \frac{(GD_M^2 + GD_L^2) \cdot N_M}{375 \cdot t_d} - T_L$ $T_{rms} = \sqrt{\frac{T_P^2 \cdot t_a + T_L^2 \cdot t_c + T_S^2 \cdot t_d}{T}}$ <p>[When a load torque is applied while stopped for a vertical ball screw:]</p> $T_{rms} = \sqrt{\frac{T_P^2 \cdot t_a + T_L^2 \cdot (T - t_a - t_d) + T_S^2 \cdot t_d}{T}}$	
System Remarks	<ul style="list-style-type: none"> <li>Feeding of coiled and sheet materials</li> <li>Roller slipping affects accuracy.</li> <li>A measuring roller pulse generator may also be installed separately.</li> </ul>	<ul style="list-style-type: none"> <li>Can be used for positioning with long travel distances.</li> <li>A separate pulse generator is often installed.</li> </ul>	

Continued on next page.

Continued from previous page.

Machine Configuration		Chains and Timing Belts	Dollies
Load Speed, $N_\ell$ ( $\text{min}^{-1}$ )	$\frac{1000 \times V_\ell}{P_B}$ <p>Load speed (m/min)</p> <p>However, <math>P_B = \pi \cdot d_p</math> [OR <math>P_B = Z_p \cdot L_p</math>]</p>	$\frac{1000 \times V_\ell}{P_B}$ <p>Load speed (m/min)</p> <p>[However, <math>P_B = \pi \cdot d_p</math>]</p>	
Speed Calculated at Motor Shaft, $N_M$ ( $\text{min}^{-1}$ )	$R \times N_\ell$	$R \times N_\ell$	
Linear Motion Section, $GD_2$ ( $\text{kg} \cdot \text{m}^2$ )	$GD^2_\ell$ Calculated at Load Shaft	$W \cdot \left(\frac{d_p}{1000}\right)^2$	$W \cdot \left(\frac{d_p}{1000}\right)^2$
	$GD^2_L$ Calculated at Motor Shaft	$GD^2_L \times \left(\frac{1}{R}\right)^2$ [OR $W \cdot \left(\frac{V_\ell}{\pi \cdot N_M}\right)^2$ ]	$GD^2_L \times \left(\frac{1}{R}\right)^2$ [OR $W \cdot \left(\frac{V_\ell}{\pi \cdot N_M}\right)^2$ ]
Load Torque ( $\text{kg} \cdot \text{m}$ )	$T_\ell$ Calculated at Load Shaft	$\{\mu \cdot (W + F_v) + F_h\} \cdot \frac{d_p}{2000}$	$C \cdot W \cdot \frac{d_p}{2 \times 10^6}$
	$T_L$ Calculated at Motor Shaft	$T_\ell \times \frac{1}{R} \times \frac{1}{\eta}$ Mechanical efficiency [OR $\frac{\{\mu \cdot (W + F_v) + F_h\} \cdot V_\ell}{2\pi \cdot N_M \cdot \eta}$ ]	$T_\ell \times \frac{1}{R} \times \frac{1}{\eta}$ Mechanical efficiency [OR $\frac{C \cdot W \cdot V_\ell}{2 \times 10^3 \times \pi \times N_M \cdot \eta}$ ]
Load Moving Power, $P_O$ (kW)	$\frac{\{\mu \cdot (W + F_v) + F_h\} \cdot V_\ell}{6120 \times \eta}$	$\frac{C \cdot W \cdot V_\ell}{6120 \times 10^3 \times \eta}$	
Load Acceleration Power	$\frac{GD^2_\ell \cdot N_\ell^2}{365 \times 10^3 \times t_a}$ Acceleration time (s)	$\frac{GD^2_\ell \cdot N_\ell^2}{365 \times 10^3 \times t_a}$ Acceleration time (s)	
Starting Torque, $T_P$ ( $\text{kg} \cdot \text{m}$ ) Deceleration Torque, $T_S$ ( $\text{kg} \cdot \text{m}$ ) Effective Torque Value, $T_{rms}$ ( $\text{kg} \cdot \text{m}$ )		$T_P = \frac{(GD^2_M + GD^2_L) \cdot N_M}{375 \cdot t_a} + T_L$ $T_S = \frac{(GD^2_M + GD^2_L) \cdot N_M}{375 \cdot t_d} - T_L$ $T_{rms} = \sqrt{\frac{T_P^2 \cdot t_a + T_L^2 \cdot t_c + T_S^2 \cdot t_d}{T}}$ <p>(When a load torque is applied while stopped for a vertical ball screw:</p> $T_{rms} = \sqrt{\frac{T_P^2 \cdot t_a + T_L^2 \cdot (T - t_a - t_d) + T_S^2 \cdot t_d}{T}}$	
System Remarks	<ul style="list-style-type: none"> <li>Positioning of conveyors</li> <li>Chain looseness, movement, and pitch error are problems (not suitable for frequent use).</li> <li>Radial load for overtightened belt chains</li> </ul>	<ul style="list-style-type: none"> <li>Dolly slipping</li> </ul>	

## Revision History

The revision dates and numbers of the revised manuals are given on the bottom of the back cover.

MANUAL NO. SIEP S800001 86B <1>-0  
 WEB revision number  
 Revision number  
 Published in Japan September 2015  
 Date of publication

Date of Publication	Rev. No.	Web Rev. No.	Section	Revised Contents
September 2023	<5>	0	Preface, 1.2, 6.1.4	Partly revised.
			Back cover	Revision: Address
May 2017	<4>	0	Preface	Revision: European Directives
			1.3.1	Revision: Information on Model Designation
			4.2.2, 5.2.2	Addition: Notes for Allowable Load Moment of Inertia
			Back cover	Revision: Address
February 2017	<3>	0	Preface	Partly revised.
			1.4, Chapter 4	Addition: SGM7A-70D□F
			1.4, Chapter 5	Addition: SGM7G-55D□F, -75D□F, -1AD□F, -1ED□F, -30D□R, and -44D□R
			Back cover	Revision: Address
June 2016	<2>	0	All chapters	Addition: SGD7W
			Chapters 3, 4, and 5	Deletion: Information on SigmaJunmaSize+
				Addition: Servomotor connector rotational angles
			Chapter 4	Addition: SGM7A-40 and -50
			Chapter 5	Addition: SGM7G-44
				Addition: High-speed Servomotors
Back cover	Revision: Address			
September 2015	<1>	0	Preface	Partly revised.
			Back cover	Revision: Address
June 2015	-	-	-	First edition

# Σ-7-Series AC Servo Drive Rotary Servomotor with 400 V-Input Power Product Manual

---

**IRUMA BUSINESS CENTER (SOLUTION CENTER)**

480, Kamifujisawa, Iruma, Saitama, 358-8555, Japan  
Phone: +81-4-2962-5151 Fax: +81-4-2962-6138  
www.yaskawa.co.jp

**YASKAWA AMERICA, INC.**

2121, Norman Drive South, Waukegan, IL 60085, U.S.A.  
Phone: +1-800-YASKAWA (927-5292) or +1-847-887-7000 Fax: +1-847-887-7310  
www.yaskawa.com

**YASKAWA ELÉTRICO DO BRASIL LTDA.**

777, Avenida Piraporinha, Diadema, São Paulo, 09950-000, Brasil  
Phone: +55-11-3585-1100 Fax: +55-11-3585-1187  
www.yaskawa.com.br

**YASKAWA EUROPE GmbH**

Philipp-Reis-Str. 6, 65795 Hattersheim am Main, Germany  
Phone: +49-6196-569-300 Fax: +49-6196-569-398  
www.yaskawa.eu.com E-mail: info@yaskawa.eu.com

**YASKAWA ELECTRIC KOREA CORPORATION**

6F, 112, LS-ro, Dongan-gu, Anyang-si, Gyeonggi-do, Korea  
Phone: +82-31-8015-4224 Fax: +82-31-8015-5034  
www.yaskawa.co.kr

**YASKAWA ASIA PACIFIC PTE. LTD.**

30A, Kallang Place, #06-01, 339213, Singapore  
Phone: +65-6282-3003 Fax: +65-6289-3003  
www.yaskawa.com.sg

**YASKAWA ELECTRIC (THAILAND) CO., LTD.**

59, 1F-5F, Flourish Building, Soi Ratchadapisek 18, Ratchadapisek Road, Huaykwang, Bangkok, 10310, Thailand  
Phone: +66-2-017-0099 Fax: +66-2-017-0799  
www.yaskawa.co.th

**YASKAWA ELECTRIC (CHINA) CO., LTD.**

22F, Link Square 1, No.222, Hubin Road, Shanghai, 200021, China  
Phone: +86-21-5385-2200 Fax: +86-21-5385-3299  
www.yaskawa.com.cn

**YASKAWA ELECTRIC (CHINA) CO., LTD. BEIJING OFFICE**

Room 1011, Tower W3 Oriental Plaza, No.1, East Chang An Avenue,  
Dong Cheng District, Beijing, 100738, China  
Phone: +86-10-8518-4086 Fax: +86-10-8518-4082

**YASKAWA ELECTRIC TAIWAN CORPORATION**

12F, No. 207, Section 3, Beishin Road, Shindian District, New Taipei City 23143, Taiwan  
Phone: +886-2-8913-1333 Fax: +886-2-8913-1513 or +886-2-8913-1519  
www.yaskawa.com.tw

---

**YASKAWA****YASKAWA ELECTRIC CORPORATION**

In the event that the end user of this product is to be the military and said product is to be employed in any weapons systems or the manufacture thereof, the export will fall under the relevant regulations as stipulated in the Foreign Exchange and Foreign Trade Regulations. Therefore, be sure to follow all procedures and submit all relevant documentation according to any and all rules, regulations and laws that may apply. Specifications are subject to change without notice for ongoing product modifications and improvements.

© 2015 YASKAWA ELECTRIC CORPORATION

MANUAL NO. SIEP S800001 86F <5>-0

Published in Japan September 2023

23-4-19

Original instructions